

MCT6 MCT61 MCT62

DESCRIPTION

The MCT6X Optocouplers have two channels for density applications. For four channel applications, two-packages fit into a standard 16-pin DIP socket. Each channel is an NPN silicon planar phototransistor optically coupled to a gallium arsenide infrared emitting diode.

FEATURES

- Two isolated channels per package
- Two packages fit into a 16 lead DIP socket
- Choice of three current transfer ratios
- Underwriters Laboratory (U.L.) recognized File E90700

APPLICATIONS

- AC Line/Digital Logic - isolate high voltage transients
- Digital Logic/Digital Logic - Eliminate spurious grounds
- Digital Logic/AC Triac Control - isolate high voltage transients
- Twisted pair line receiver - Eliminate ground loop feedthrough
- Telephone/Telegraph line receiver - isolate high voltage transients
- High Frequency Power Supply Feedback Control - Maintain floating grounds and transients
- Relay contact monitor - isolate floating grounds and transients
- Power supply monitor - Isolate transients

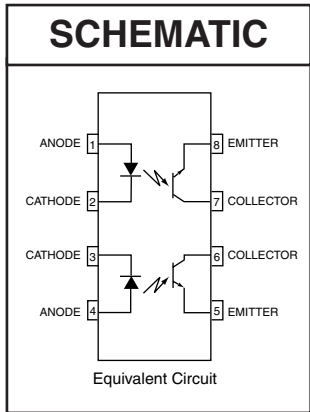
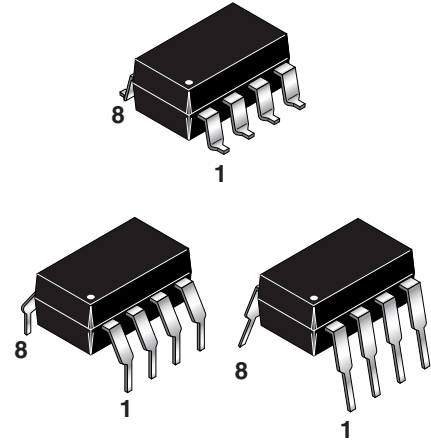

ABSOLUTE MAXIMUM RATINGS			
Rating	Symbol	Value	Unit
EMITTER (Each channel)			
Forward Current - Continuous	I_F	60	mA
Forward Current - Peak (PW = 1μs, 300pps)	$I_F(pk)$	3	A
Reverse Voltage	V_R	3.0	V
LED Power Dissipation @ $T_A = 25^\circ C$	P_D	100	mW
Derate above 25°C (Total Input)		1.3	mW/°C
DETECTOR (Each channel)			
Collector Current - Continuous	I_C	30	mA
Detector Power Dissipation @ $T_A = 25^\circ C$	P_D	150	mW
Derate above 25°C		2.0	mW/°C
TOTAL DEVICE			
Storage Temperature	T_{STG}	-55 to +150	°C
Operating Temperature	T_{OPR}	-55 to +100	°C
Lead Solder Temperature	T_{SOL}	250 for 10 sec	°C
Total Device Power Dissipation @ $T_A = 25^\circ C$	P_D	400	mW
Derate above 25°C		5.33	mW/°C

MCT6 MCT61 MCT62

ELECTRICAL CHARACTERISTICS ($T_A = 25^\circ\text{C}$ Unless otherwise specified.)

INDIVIDUAL COMPONENT CHARACTERISTICS

Parameter	Test Conditions	Symbol	Min	Typ**	Max	Unit
EMITTER						
Input Forward Voltage	($I_F = 20\text{ mA}$)	V_F		1.2	1.5	V
Reverse Voltage	($I_R = 10\ \mu\text{A}$)	V_R	3.0	25		V
Reverse Current	($V_R = 5\text{ V}$)	I_R		0.001	10	μA
Junction Capacitance	($V_F = 0\text{ V}$, $f = 1\text{ MHz}$)	C_J		50		pF
DETECTOR						
Collector-Emitter Breakdown Voltage	($I_C = 1.0\text{ mA}$, $I_F = 0$)	BV_{CEO}	30	85		V
Emitter-Collector Breakdown Voltage	($I_E = 100\ \mu\text{A}$, $I_F = 0$)	BV_{ECO}	6	13		V
Collector-Emitter Dark Current	($V_{CE} = 10\text{ V}$, $I_F = 0$)	I_{CEO}		5	100	nA
Capacitance	($V_{CE} = 0\text{ V}$, $f = 1\text{ MHz}$)	C_{CE}		8		pF

TRANSFER CHARACTERISTICS

AC Characteristic	Test Conditions	Symbol	Min	Typ**	Max	Units
SWITCHING TIMES						
Non-Saturated Turn-on Time	($R_L = 100\ \Omega$, $I_C = 2\text{ mA}$, $V_{CC} = 10\text{ V}$)	t_{on}		2.4		μs
Non-Saturated Turn-off Time	($R_L = 100\ \Omega$, $I_C = 2\text{ mA}$, $V_{CC} = 10\text{ V}$)	t_{off}		2.4		μs

TRANSFER CHARACTERISTICS

DC Characteristic	Test Conditions	Symbol	Min	Typ**	Max	Units
Current Transfer Ratio, Collector-Emitter	($I_F = 10\text{ mA}$, $V_{CE} = 10\text{ V}$)	CTR	20			%
			50			
	($I_F = 5\text{ mA}$, $V_{CE} = 5\text{ V}$)		100			
Saturation Voltage	($I_F = 16\text{ mA}$, $I_C = 2\text{ mA}$)	$V_{CE(sat)}$		0.15	0.40	V

ISOLATION CHARACTERISTICS

Characteristic	Test Conditions	Symbol	Min	Typ**	Max	Units
Input-Output Isolation Voltage	($I_{I-O} \leq 1\ \mu\text{A}$, 1 min.)	V_{ISO}	5300			Vac(rms)
Isolation Resistance	($V_{I-O} = 500\text{ VDC}$)	R_{ISO}	10^{11}			Ω
Isolation Capacitance	($f = 1\text{ MHz}$)	C_{ISO}		0.5		pf

** All typicals at $T_A = 25^\circ\text{C}$

MCT6 MCT61 MCT62

Normalized CTR vs. Forward Current

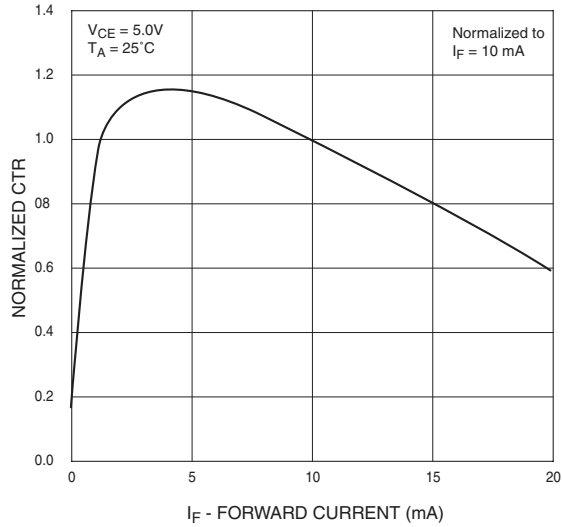

Normalized CTR vs. Ambient Temperature

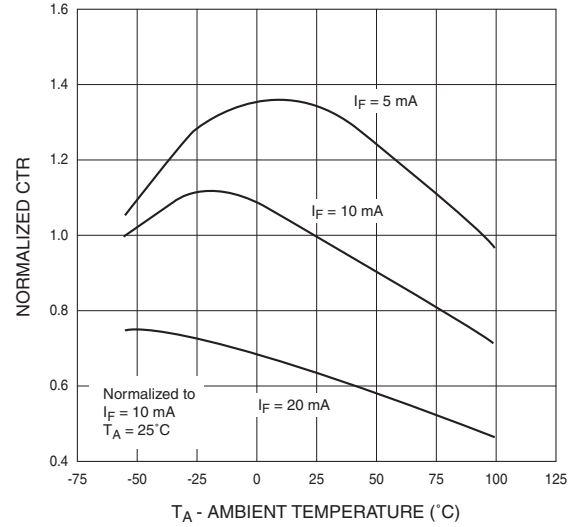

Dark Current vs. Ambient Temperature

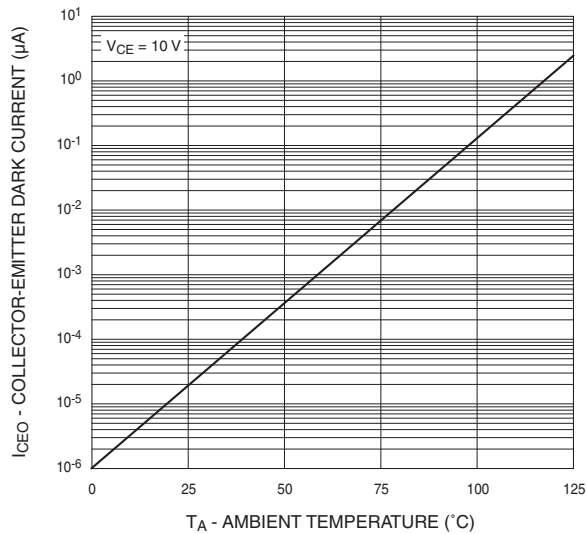

MCT6 MCT61 MCT62

Switching Speed vs. Load Resistor

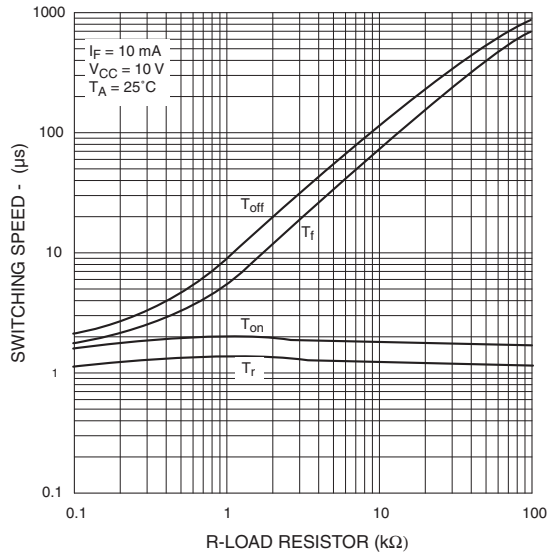

LED Forward Voltage vs. Forward Current

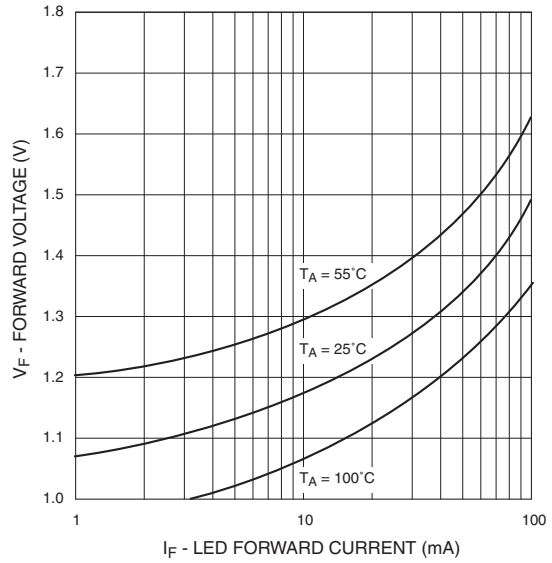

Collector-Emitter Saturation Voltage vs Collector Current

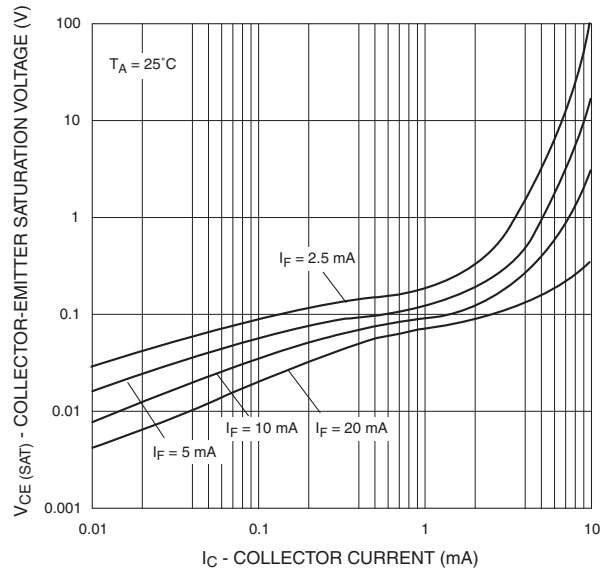

MCT6 MCT61 MCT62

Package Dimensions (Through Hole)

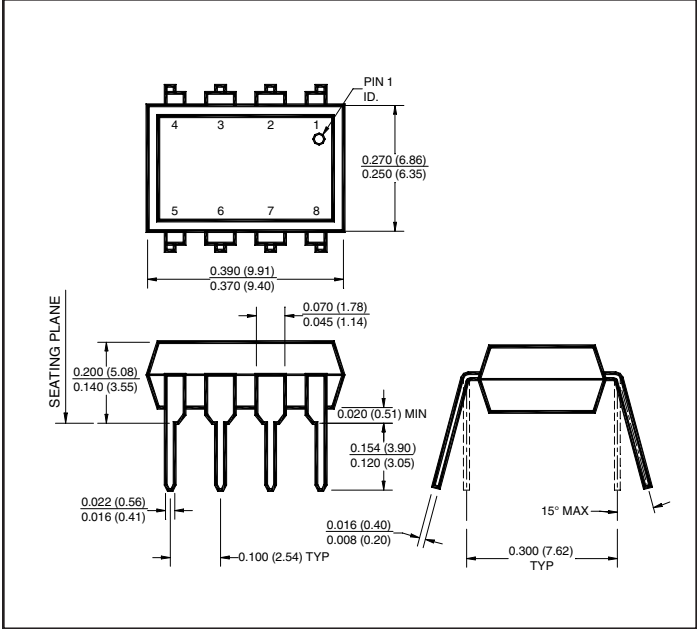

Package Dimensions (Surface Mount)

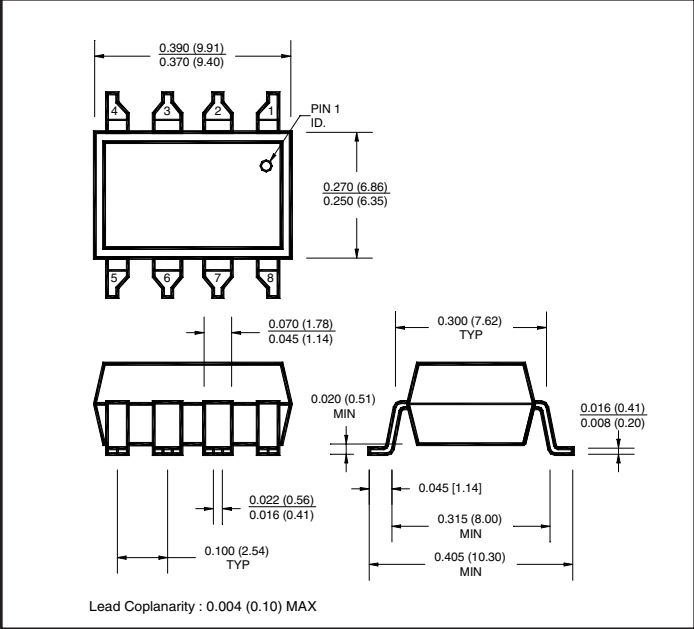

Package Dimensions (0.4" Lead Spacing)

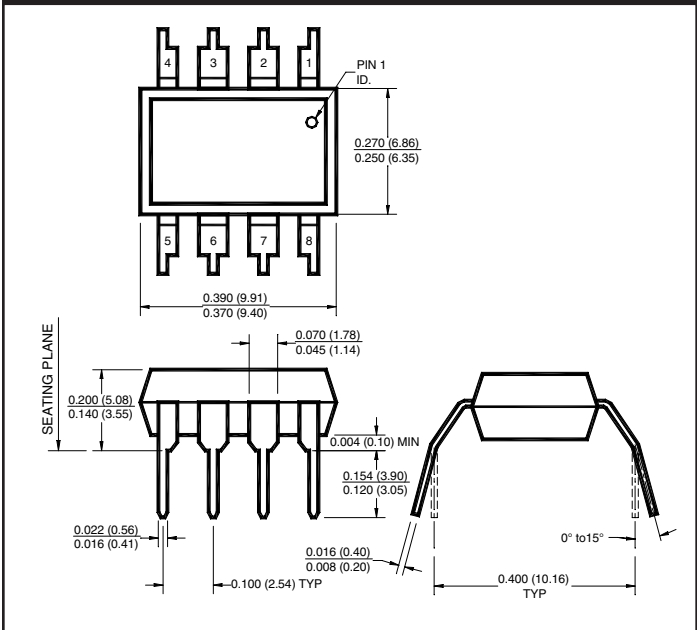

8 - Pin Dip

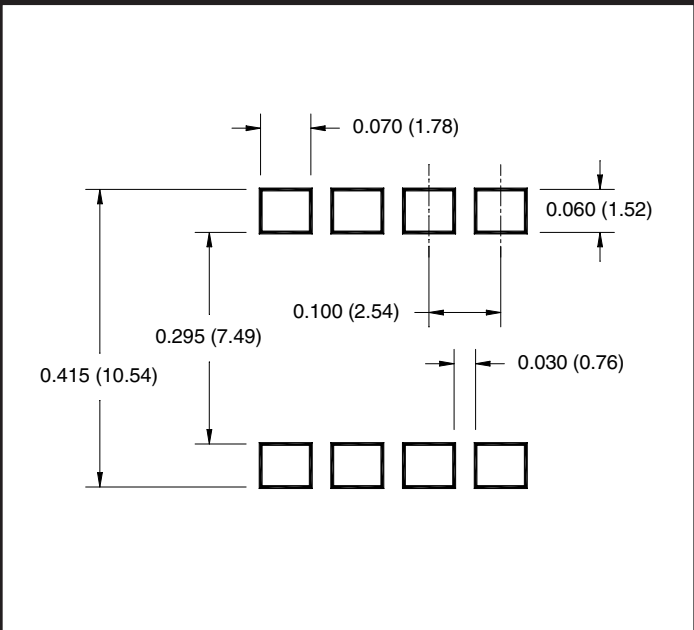

NOTE
All dimensions are in inches (millimeters)

MCT6 MCT61 MCT62

ORDERING INFORMATION

Option	Order Entry Identifier	Description
S	.S	Surface Mount Lead Bend
SD	.SD	Surface Mount; Tape and reel
W	.W	0.4" Lead Spacing
300	.300	VDE 0084
300W	.300W	VDE 0084 and 0.4" Lead Spacing
3S	.3S	VDE 0084 and Surface Mount Lead Bend
3SD	.3SD	VDE 0084 and Surface Mount Lead Bend Tape and Reel

QT Carrier Tape Specifications ("D" Taping Orientation)

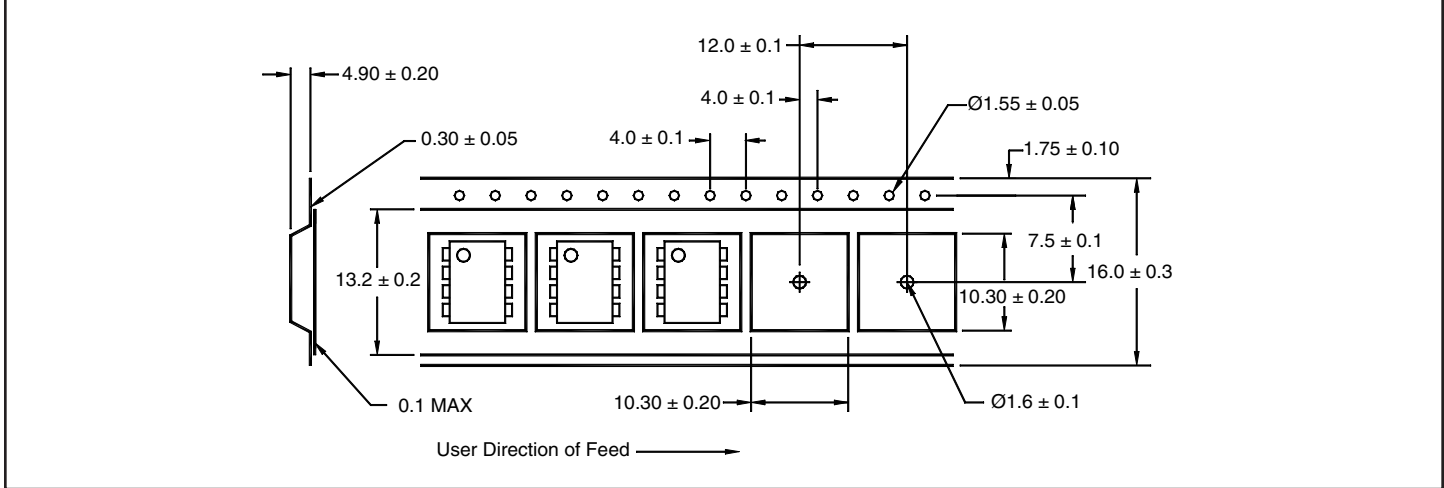

DISCLAIMER

FAIRCHILD SEMICONDUCTOR RESERVES THE RIGHT TO MAKE CHANGES WITHOUT FURTHER NOTICE TO ANY PRODUCTS HEREIN TO IMPROVE RELIABILITY, FUNCTION OR DESIGN. FAIRCHILD DOES NOT ASSUME ANY LIABILITY ARISING OUT OF THE APPLICATION OR USE OF ANY PRODUCT OR CIRCUIT DESCRIBED HEREIN; NEITHER DOES IT CONVEY ANY LICENSE UNDER ITS PATENT RIGHTS, NOR THE RIGHTS OF OTHERS.

LIFE SUPPORT POLICY

FAIRCHILD'S PRODUCTS ARE NOT AUTHORIZED FOR USE AS CRITICAL COMPONENTS IN LIFE SUPPORT DEVICES OR SYSTEMS WITHOUT THE EXPRESS WRITTEN APPROVAL OF THE PRESIDENT OF FAIRCHILD SEMICONDUCTOR CORPORATION. As used herein:

1. Life support devices or systems are devices or systems which, (a) are intended for surgical implant into the body, or (b) support or sustain life, and (c) whose failure to perform when properly used in accordance with instructions for use provided in labeling, can be reasonably expected to result in a significant injury of the user.
2. A critical component in any component of a life support device or system whose failure to perform can be reasonably expected to cause the failure of the life support device or system, or to affect its safety or effectiveness.

This datasheet has been download from:

www.datasheetcatalog.com

Datasheets for electronics components.