

**MOTOROLA
SEMICONDUCTOR
TECHNICAL DATA**

HEX THREE-STATE BUFFER INVERTERS

This series of devices combines three features usually found desirable in bus-oriented systems: 1) High impedance logic inputs insure that these devices do not seriously load the bus; 2) Three-state logic configuration allows buffers not being utilized to be effectively removed from the bus; 3) Schottky technology allows high-speed operation.

The noninverting MC8T97/MC6887 and inverting MC8T98/MC6888 provide two Enable inputs — one controlling four buffers and the other controlling the remaining two buffers.

The units are well-suited for Address buffers on the MC6800 or similar microprocessor application.

- High Speed — 8.0 ns (Typ)
- Three-State Logic Configuration
- Single +5 V Power Supply Requirement
- Compatible with 74LS Logic or MC6800 Microprocessor Systems
- High Impedance PNP Inputs Assure Minimal Loading of the Bus

MC8T97 (MC6887)
MC8T98 (MC6888)

**HEX THREE-STATE
BUFFER/INVERTERS**

**MONOLITH SCHOTTKY
INTEGRATED CIRCUITS**



**L SUFFIX
CERAMIC PACKAGE
CASE 620**



**P SUFFIX
PLASTIC PACKAGE
CASE 648**

INPUT EQUIVALENT CIRCUIT

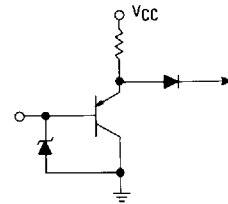

OUTPUT EQUIVALENT CIRCUIT

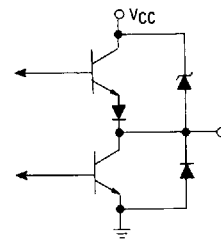

ORDERING INFORMATION

(Temperature Range = 0 to + 75°C)

Device	Alternate	Package
MC8T97L	MC6887L	Ceramic DIP
MC8T98L	MC6888L	Ceramic DIP
MC8T97P	MC6887P	Plastic DIP
MC8T98P	MC6888P	Plastic DIP

MICROPROCESSOR BUS EXTENDER APPLICATION

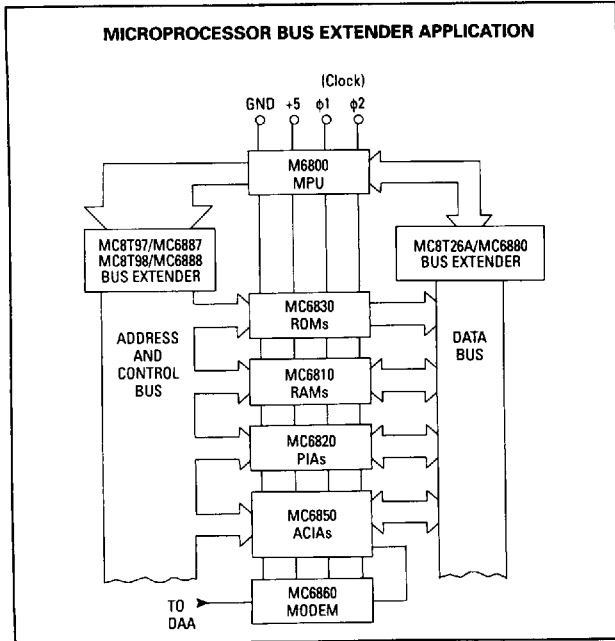

7

MC8T97, MC8T98

MAXIMUM RATINGS (T_A = 25°C unless otherwise noted.)

Rating	Symbol	Value	Unit
Power Supply Voltage	V _{CC}	8.0	V _{dc}
Input Voltage	V _I	5.5	V _{dc}
Operating Ambient Temperature Range	T _A	0 to +75	°C
Storage Temperature Range	T _{stg}	-65 to +150	°C
Operating Junction Temperature	T _J		°C
Plastic Package		150	
Ceramic Package		175	

MC8T97/MC6887

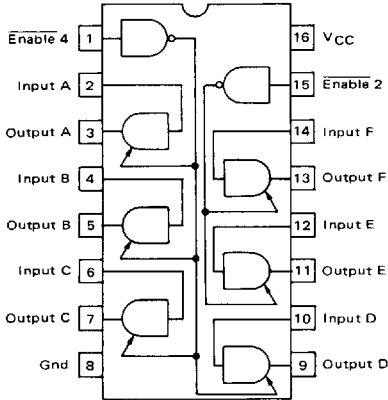

Enable	Input	Output
L	L	L
L	H	H
H	X	Z

L = Low Logic State
 H = High Logic State
 Z = Third (High Impedance) State
 X = Irrelevant

MC8T98/MC6888

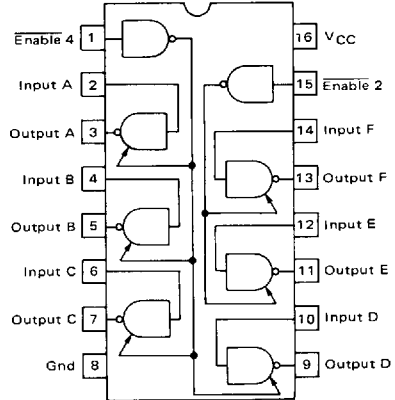

Enable	Input	Output
L	L	H
L	H	L
H	X	Z

MC8T97, MC8T98

ELECTRICAL CHARACTERISTICS (Unless otherwise noted, $0^{\circ}\text{C} \leq T_A \leq 75^{\circ}\text{C}$ and $4.75\text{ V} \leq V_{CC} \leq 5.25\text{ V}$)

Characteristics	Symbol	Min	Typ	Max	Unit
Input Voltage High Logic State ($V_{CC} = 4.75\text{ V}$, $T_A = 25^{\circ}\text{C}$) Low Logic State ($V_{CC} = 4.75\text{ V}$, $T_A = 25^{\circ}\text{C}$)	V_{IH} V_{IL}	2.0 —	— —	— 0.8	V
Input Current — High Logic State ($V_{CC} = 5.25\text{ V}$, $V_{IH} = 2.4\text{ V}$) Low Logic State ($V_{CC} = 5.25\text{ V}$, $V_{IL} = 0.5\text{ V}$, $V_{IL(E)} = 0.5\text{ V}$) High Impedance State ($V_{CC} = 5.25\text{ V}$, $V_{IL} = 0.5\text{ V}$, $V_{IH(E)} = 2.0\text{ V}$)	I_{IH} I_{IL} $I_{IH(E)}$	— — —	— — —	40 -400 -40	μA
Output Voltage High Logic State ($V_{CC} = 4.75\text{ V}$, $I_{OH} = -5.2\text{ mA}$) Low Logic State ($I_{OL} = 48\text{ mA}$)	V_{OH} V_{OL}	2.4 —	— —	— 0.5	V
Output Voltage — High Impedance State ($V_{CC} = 5.25\text{ V}$, $V_{OH} = 2.4\text{ V}$) ($V_{CC} = 5.25\text{ V}$, $V_{OL} = 0.5\text{ V}$)	I_{OZ}	— —	— —	40 -40	μA
Output Short Circuit Current ($V_{CC} = 5.25\text{ V}$, $V_O = 0$, only one output can be shorted at a time)	I_{OS}	-40	-80	-115	mA
Power Supply Current ($V_{CC} = 5.25\text{ V}$) MC8T97, MC6887 MC8T98, MC6888	I_{CC}	— —	65 59	98 89	mA
Input Clamp Voltage ($V_{CC} = 4.75\text{ V}$, $I_{IC} = -12\text{ mA}$)	V_{IC}	—	—	-1.5	V
Input Voltage ($I_I = 1.0\text{ mA}$)	V_I	5.5	—	—	V
Output V_{CC} Clamp Voltage ($V_{CC} = 0$, $I_{OC} = 12\text{ mA}$)	V_{OC}	—	—	1.5	V
Output Gnd Clamp Voltage ($V_{CC} = 0$, $I_{OC} = 12\text{ mA}$)	V_{OC}	—	—	-1.5	V

SWITCHING CHARACTERISTICS ($V_{CC} = 5.0\text{ V}$, $T_A = 25^{\circ}\text{C}$ unless otherwise noted.)

Characteristic	Symbol	MC8T97 MC6887			MC8T98 MC6888			Unit
		Min	Typ	Max	Min	Typ	Max	
Propagation Delay Time — High-to-Low State ($C_L = 50\text{ pF}$) ($C_L = 250\text{ pF}$) ($C_L = 375\text{ pF}$) ($C_L = 500\text{ pF}$)	t_{PHL}	3.0 — — —	— 16 20 23	12 — — —	4.0 — — —	— 15 18 22	11 — — —	ns
Propagation Delay Time — Low-to-High State ($C_L = 50\text{ pF}$) ($C_L = 250\text{ pF}$) ($C_L = 375\text{ pF}$) ($C_L = 500\text{ pF}$)	t_{PLH}	3.0 — — —	— 25 33 42	13 — — —	3.0 — — —	— 22 28 35	10 — — —	ns
Transition Time — High-to-Low State ($C_L = 250\text{ pF}$) ($C_L = 375\text{ pF}$) ($C_L = 500\text{ pF}$)	t_{THL}	— — —	10 11 14	— — —	— — —	10 13 15	— — —	ns
Transition Time — Low-to-High State ($C_L = 250\text{ pF}$) ($C_L = 375\text{ pF}$) ($C_L = 500\text{ pF}$)	t_{TLH}	— — —	32 42 60	— — —	— — —	28 38 53	— — —	ns
Propagation Delay Time — High State-to-Third State ($C_L = 5.0\text{ pF}$)	$t_{PHZ(E)}$	—	—	10	—	—	10	ns
Propagation Delay Time — Low State-to-Third State ($C_L = 5.0\text{ pF}$)	$t_{PLZ(E)}$	—	—	12	—	—	16	ns
Propagation Delay Time — Third State-to-High State ($C_L = 50\text{ pF}$)	$t_{PZH(E)}$	—	—	25	—	—	22	ns
Propagation Delay Time — Third State-to-Low State ($C_L = 50\text{ pF}$)	$t_{PZL(E)}$	—	—	25	—	—	24	ns

MC8T97, MC8T98

FIGURE 1 – TEST CIRCUIT FOR SWITCHING CHARACTERISTICS

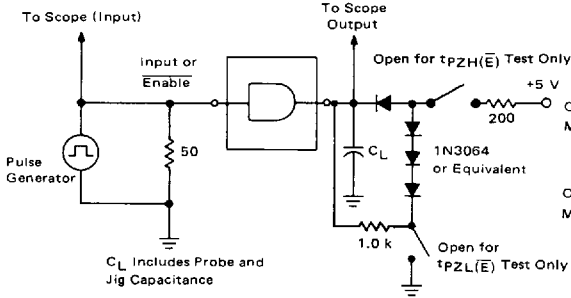

FIGURE 2 – WAVEFORMS FOR PROPAGATION DELAY TIMES INPUT TO OUTPUT

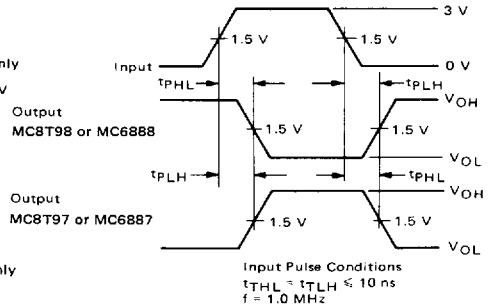
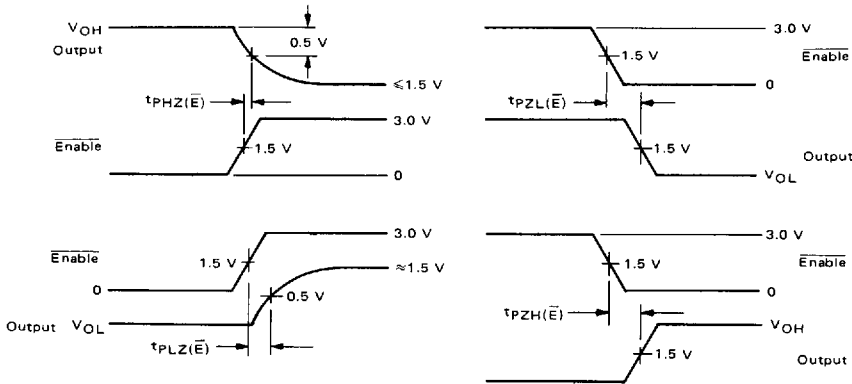

FIGURE 3 – WAVEFORMS FOR PROPAGATION DELAY TIMES – ENABLE TO OUTPUT



H = High-Logic State, L = Low-Logic State, Z = High Impedance State

This datasheet has been downloaded from:

www.DatasheetCatalog.com

Datasheets for electronic components.