

# Boca Semiconductor Corp. (BSC)

MC78LXXA (LM78LXX, KA78LXXA)

FIXED VOLTAGE REGULATOR (POSITIVE)

## 3-TERMINAL 0.1A POSITIVE VOLTAGE REGULATORS

The MC78LXX series of fixed voltage monolithic integrated circuit voltage regulators are suitable for application that required supply up to 100mA.

## FEATURES

- Maximum Output Current of 100mA
- Output Voltage of 5V, 6V, 8V, 9V, 10V, 12V, 15V, 18V and 24V
- Thermal Overload Protection
- Short Circuit Current Limiting
- Output Voltage Offered in  $\pm 5\%$  Tolerance

TO-92

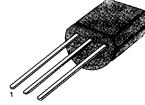

1: Output 2: GND 3: Input

8 SOP



1: Output 2: GND 3: GND 4: NC  
5: NC 6: GND 7: GND 8: Input

## ORDERING INFORMATION

Device	Package	Operating Temperature
MC78LXXACP (LM78LXXACZ) (KA78LXXAZ)	TO-92	- 45 ~ + 125°C
MC78LXXACD (KA78LXXAD)	8 SOP	0 ~ + 125°C

## BLOCK DIAGRAM

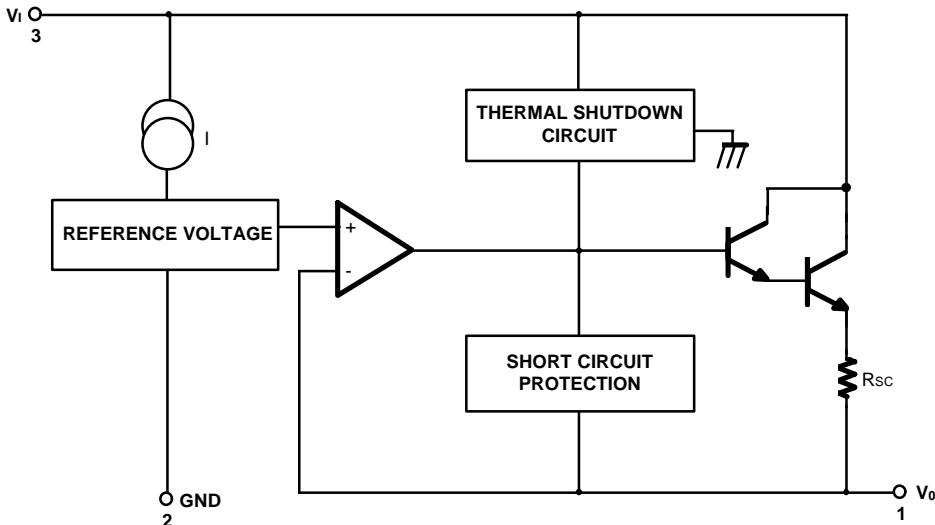

**ABSOLUTE MAXIMUM RATINGS** ( $T_A = 25^\circ\text{C}$ , unless otherwise specified)

Characteristic	Symbol	Value	Unit
Input Voltage (for $V_O = 5\text{V}, 8\text{V}$ ) (for $V_O = 12\text{V}, 15\text{V}$ )	$V_I$	30	V
		35	V
Operating Junction Temperature Range	$T_J$	0 ~ +150	$^\circ\text{C}$
Storage Temperature Range	$T_{\text{STG}}$	-65 ~ +150	$^\circ\text{C}$

**LM78L05 ELECTRICAL CHARACTERISTICS**

( $V_I = 10\text{V}$ ,  $I_O = 40\text{mA}$ ,  $0^\circ\text{C} \leq T_J \leq 125^\circ\text{C}$ ,  $C_I = 0.33\ \mu\text{F}$ ,  $C_O = 0.1\ \mu\text{F}$ , unless otherwise specified. (Note 1))

Characteristic	Symbol	Test Conditions	Min	Typ	Max	Unit
Output Voltage	$V_O$	$T_J = 25^\circ\text{C}$	4.8	5.0	5.2	V
Line Regulation	$\Delta V_O$	$T_J = 25^\circ\text{C}$	$7\text{V} \leq V_I \leq 20\text{V}$	8	150	mV
			$8\text{V} \leq V_I \leq 20\text{V}$	6	100	mV
Load Regulation	$\Delta V_O$	$T_J = 25^\circ\text{C}$	$1\text{mA} \leq I_O \leq 100\text{mA}$	11	60	mV
			$1\text{mA} \leq I_O \leq 40\text{mA}$	5.0	30	mV
Output Voltage	$V_O$	$7\text{V} \leq V_I \leq 0\text{V}$ $7\text{V} \leq V_I \leq V_{\text{MAX}}$ (Note 2)	$1\text{mA} \leq I_O \leq 40\text{mA}$		5.25	V
			$1\text{mA} \leq I_O \leq 70\text{mA}$	4.75	5.25	V
Quiescent Current	$I_Q$	$T_J = 25^\circ\text{C}$		2.0	5.5	mA
Quiescent Current Change	with line	$8\text{V} \leq V_I \leq 20\text{V}$			1.5	mA
	with load		$1\text{mA} \leq I_O \leq 40\text{mA}$		0.1	mA
Output Noise Voltage	$V_N$	$T_A = 25^\circ\text{C}$ , $10\text{Hz} \leq f \leq 100\text{KHz}$		40		$\mu\text{V}/V_O$
Temperature Coefficient of $V_O$	$\Delta V_O/\Delta T$	$I_O = 5\text{mA}$		-0.65		$\text{mV}/^\circ\text{C}$
Ripple Rejection	RR	$f = 120\text{Hz}$ , $8\text{V} \leq V_I \leq 18\text{V}$ , $T_J = 25^\circ\text{C}$	41	80		dB
Dropout Voltage	$V_D$	$T_J = 25^\circ\text{C}$		1.7		V

**LM78L06 ELECTRICAL CHARACTERISTICS**

( $V_I = 12V$ ,  $I_O = 40mA$ ,  $0^\circ C \leq T_J \leq 125^\circ C$ ,  $C_I = 0.33\mu F$ ,  $C_O = 0.1\mu F$ , unless otherwise specified. (Note 1))

Characteristic		Symbol	Test Conditions	Min	Typ	Max	Unit
Output Voltage		$V_O$	$T_J = 25^\circ C$	5.75	6.0	6.25	V
Line Regulation		$\Delta V_O$	$T_J = 25^\circ C$	$8.5V < V_I < 20V$	64	175	mV
				$9V \geq V_I \geq 20V$	54	125	mV
Load Regulation		$\Delta V_O$	$T_J = 25^\circ C$	$1mA < I_O < 100mA$	12.8	80	mV
				$1mA < I_O < 70mA$	5.8	40	mV
Output Voltage		$V_O$	$8.5 < V_I < 20V$ , $1mA < I_O < 40mA$	5.7		6.3	V
			$8.5 < V_I < V_{MAX}(\text{Note})$ , $1mA < I_O < 70mA$	5.7		6.3	
Quiescent Current		$I_Q$	$T_J = 25^\circ C$		3.9	6.0	mA
			$T_J = 125^\circ C$			5.5	
Quiescent Current Change	with line	$\Delta I_Q$	$9 < V_I < 20V$			1.5	mA
	with load	$\Delta I_Q$	$1mA < I_O < 40mA$			0.1	
Output Noise Voltage		$V_N$	$T_A = 25^\circ C$ , $10Hz < f < 100KHz$		40		$\mu V/V_O$
Temperature Coefficient of $V_O$		$\Delta V_O/\Delta T$	$I_O = 5mA$		0.75		$mV/^\circ C$
Ripple Rejection		RR	$f = 120Hz$ , $10V < V_I < 20V$ , $T_J = 25^\circ C$	40	46		dB
Dropout Voltage		$V_D$	$T_J = 25^\circ C$		1.7		V

**LM78L08 ELECTRICAL CHARACTERISTICS**

( $V_I = 14V$ ,  $I_O = 40mA$ ,  $0^\circ C \leq T_J \leq 125^\circ C$ ,  $C_I = 0.33\mu F$ ,  $C_O = 0.1\mu F$ , unless otherwise specified. (Note 1))

Characteristic		Symbol	Test Conditions	Min	Typ	Max	Unit
Output Voltage		$V_O$	$T_J = 25^\circ C$	7.7	8.0	8.3	V
Line Regulation		$\Delta V_O$	$T_J = 25^\circ C$	$10.5V \leq V_I \leq 23V$	10	175	mV
				$11V \leq V_I \leq 23V$	8	125	mV
Load Regulation		$\Delta V_O$	$T_J = 25^\circ C$	$1mA \leq I_O \leq 100mA$	15	80	mV
				$1mA \leq I_O \leq 40mA$	8.0	40	mV
Output Voltage		$V_O$	$10.5V \leq V_I \leq 23V$	7.6		8.4	V
			$10.5V \leq V_I \leq V_{MAX}(\text{Note 2})$	7.6		8.4	V
Quiescent Current		$I_Q$	$T_J = 25^\circ C$		2.0	5.5	mA
Quiescent Current Change	with line	$\Delta I_Q$	$11V \leq V_I \leq 23V$			1.5	mA
	with load	$\Delta I_Q$	$1mA \leq I_O \leq 40mA$			0.1	mA
Output Noise Voltage		$V_N$	$T_A = 25^\circ C$ , $10Hz \leq f \leq 100KHz$		60		$\mu V/V_O$
Temperature Coefficient of $V_O$		$\Delta V_O/\Delta T$	$I_O = 5mA$		-0.8		$mV/^\circ C$
Ripple Rejection		RR	$f = 120Hz$ , $11V \leq V_I \leq 21V$ , $T_J = 25^\circ C$	39	70		dB
Dropout Voltage		$V_D$	$T_J = 25^\circ C$		1.7		V

**LM78L09 ELECTRICAL CHARACTERISTICS**(V<sub>I</sub> = 15V, I<sub>O</sub> = 40mA, 0°C ≤ T<sub>J</sub> ≤ 125°C, C<sub>I</sub> = 0.33 μF, C<sub>O</sub> = 0.1μF, unless otherwise specified. (Note 1))

Characteristic		Symbol	Test Conditions	Min	Typ	Max	Unit
Output Voltage		V <sub>O</sub>	T <sub>J</sub> = 25°C	8.64	9.0	9.36	V
Line Regulation		ΔV <sub>O</sub>	T <sub>J</sub> = 25°C	11.5V ≤ V <sub>I</sub> ≤ 24V	90	200	mV
				13V ≤ V <sub>I</sub> ≤ 24V	100	150	mV
Load Regulation		ΔV <sub>O</sub>	T <sub>J</sub> = 25°C	1mA ≤ I <sub>O</sub> ≤ 100mA	20	90	mV
				1mA ≤ I <sub>O</sub> ≤ 40mA	10	45	mV
Output Voltage		V <sub>O</sub>	11.5V ≤ V <sub>I</sub> ≤ 24V	1mA ≤ I <sub>O</sub> ≤ 40mA	8.55	9.45	V
			11.5V ≤ V <sub>I</sub> ≤ V <sub>MAX</sub> (Note 2)	1mA ≤ I <sub>O</sub> ≤ 70mA	8.55	9.45	V
Quiescent Current		I <sub>O</sub>	T <sub>J</sub> = 25°C		2.1	6.0	mA
Quiescent Current Change	with line	ΔI <sub>O</sub>	13V ≤ V <sub>I</sub> ≤ 24V			1.5	mA
	with load	ΔI <sub>O</sub>	1mA ≤ I <sub>O</sub> ≤ 40mA			0.1	mA
Output Noise Voltage		V <sub>N</sub>	T <sub>A</sub> = 25°C, 10Hz ≤ f ≤ 100KHz		70		μV/V <sub>O</sub>
Temperature Coefficient of V <sub>O</sub>		ΔV <sub>O</sub> /ΔT	I <sub>O</sub> = 5mA		-0.9		mV/°C
Ripple Rejection		RR	f = 120Hz, 12V ≤ V <sub>I</sub> ≤ 22V, T <sub>J</sub> = 25°C	38	44		dB
Dropout Voltage		V <sub>D</sub>	T <sub>J</sub> = 25°C		1.7		V

**LM78L10 ELECTRICAL CHARACTERISTICS**(V<sub>I</sub> = 16V, I<sub>O</sub> = 40mA, 0°C < T<sub>J</sub> < 125°C, C<sub>I</sub> = 0.33 μF, C<sub>O</sub> = 0.1μF, unless otherwise specified. (Note 1))

Characteristic		Symbol	Test Conditions	Min	Typ	Max	Unit
Output Voltage		V <sub>O</sub>	T <sub>J</sub> = 25°C	9.6	10.0	10.4	V
Line Regulation		ΔV <sub>O</sub>	T <sub>J</sub> = 25°C	12.5 < V <sub>I</sub> < 25V	100	220	mV
				14V ≥ V <sub>I</sub> ≥ 25V	100	170	mV
Load Regulation		ΔV <sub>O</sub>	T <sub>J</sub> = 25°C	1mA < I <sub>O</sub> < 100mA	20	94	mV
				1mA < I <sub>O</sub> < 70mA	10	47	mV
Output Voltage		V <sub>O</sub>	12.5 < V <sub>I</sub> < 25V, 1mA < I <sub>O</sub> < 40mA	9.5		10.5	V
			12.5 < V <sub>I</sub> < V <sub>MAX</sub> (Note), 1mA < I <sub>O</sub> < 70mA	9.5		10.5	
Quiescent Current		I <sub>O</sub>	T <sub>J</sub> = 25°C		4.2	6.5	mA
			T <sub>J</sub> = 125°C			6.0	
Quiescent Current Change	with line	ΔI <sub>O</sub>	12.5 < V <sub>I</sub> < 25V			1.5	mA
	with load	ΔI <sub>O</sub>	1mA < I <sub>O</sub> < 40mA			0.1	
Output Noise Voltage		V <sub>N</sub>	T <sub>A</sub> = 25°C, 10Hz < f < 100KHz		74		μV/V <sub>O</sub>
Temperature Coefficient of V <sub>O</sub>		ΔV <sub>O</sub> /ΔT	I <sub>O</sub> = 5mA		0.95		mV/°C
Ripple Rejection		RR	f = 120Hz, 15V < V <sub>I</sub> < 25V, T <sub>J</sub> = 25°C	38	43		dB
Dropout Voltage		V <sub>D</sub>	T <sub>J</sub> = 25°C		1.7		V

**LM78L12 ELECTRICAL CHARACTERISTICS**(V<sub>I</sub> = 19V, I<sub>O</sub> = 40mA, 0 °C ≤ T<sub>J</sub> ≤ 125 °C, C<sub>I</sub> = 0.33 μF, C<sub>O</sub> = 0.1 μF, unless otherwise specified. (Note 1))

Characteristic		Symbol	Test Conditions	Min	Typ	Max	Unit
Output Voltage		V <sub>O</sub>	T <sub>J</sub> = 25 °C	11.5	12	12.5	V
Line Regulation		ΔV <sub>O</sub>	T <sub>J</sub> = 25 °C	14.5V ≤ V <sub>I</sub> ≤ 27V	20	250	mV
				16V ≤ V <sub>I</sub> ≤ 27V	15	200	mV
Load Regulation		ΔV <sub>O</sub>	T <sub>J</sub> = 25 °C	1mA ≤ I <sub>O</sub> ≤ 100mA	20	100	mV
				1mA ≤ I <sub>O</sub> ≤ 40mA	10	50	mV
Output Voltage		V <sub>O</sub>	14.5V ≤ V <sub>I</sub> ≤ 27V	1mA ≤ I <sub>O</sub> ≤ 40mA	11.4	12.6	V
			14.5V ≤ V <sub>I</sub> ≤ V <sub>MAX</sub> (Note 2)	1mA ≤ I <sub>O</sub> ≤ 70mA	11.4	12.6	V
Quiescent Current		I <sub>O</sub>	T <sub>J</sub> = 25 °C		2.1	6.0	mA
Quiescent Current Change	with line	ΔI <sub>O</sub>	16V ≤ V <sub>I</sub> ≤ 27V			1.5	mA
	with load	ΔI <sub>O</sub>	1mA ≤ I <sub>O</sub> ≤ 40mA			0.1	mA
Output Noise Voltage		V <sub>N</sub>	T <sub>A</sub> = 25 °C, 10Hz ≤ f ≤ 100KHz		80		μV/V <sub>O</sub>
Temperature Coefficient of V <sub>O</sub>		ΔV <sub>O</sub> /ΔT	I <sub>O</sub> = 5mA		-1.0		mV/°C
Ripple Rejection		RR	f = 120Hz, 15V ≤ V <sub>I</sub> ≤ 25V, T <sub>J</sub> = 25 °C	37	65		dB
Dropout Voltage		V <sub>D</sub>	T <sub>J</sub> = 25 °C		1.7		V

**LM78L15 ELECTRICAL CHARACTERISTICS**(V<sub>I</sub> = 23V, I<sub>O</sub> = 40mA, 0 °C ≤ T<sub>J</sub> ≤ 125 °C, C<sub>I</sub> = 0.33 μF, C<sub>O</sub> = 0.1 μF, unless otherwise specified. (Note 1))

Characteristic		Symbol	Test Conditions	Min	Typ	Max	Unit
Output Voltage		V <sub>O</sub>	T <sub>J</sub> = 25 °C	14.4	15	15.6	V
Line Regulation		ΔV <sub>O</sub>	T <sub>J</sub> = 25 °C	17.5V ≤ V <sub>I</sub> ≤ 30V	25	300	mV
				20V ≤ V <sub>I</sub> ≤ 30V	20	250	mV
Load Regulation		ΔV <sub>O</sub>	T <sub>J</sub> = 25 °C	1mA ≤ I <sub>O</sub> ≤ 100mA	25	150	mV
				1mA ≤ I <sub>O</sub> ≤ 40mA	12	75	mV
Output Voltage		V <sub>O</sub>	17.5V ≤ V <sub>I</sub> ≤ 30V	1mA ≤ I <sub>O</sub> ≤ 40mA	14.25	15.75	V
			17.5V ≤ V <sub>I</sub> ≤ V <sub>MAX</sub> (Note 2)	1mA ≤ I <sub>O</sub> ≤ 70mA	14.25	15.75	V
Quiescent Current		I <sub>O</sub>	T <sub>J</sub> = 25 °C		2.1	6.0	mA
Quiescent Current Change	with line	ΔI <sub>O</sub>	20V ≤ V <sub>I</sub> ≤ 30V			1.5	mA
	with load	ΔI <sub>O</sub>	1mA ≤ I <sub>O</sub> ≤ 40mA			0.1	mA
Output Noise Voltage		V <sub>N</sub>	T <sub>A</sub> = 25 °C, 10Hz ≤ f ≤ 100KHz		90		μV/V <sub>O</sub>
Temperature Coefficient of V <sub>O</sub>		ΔV <sub>O</sub> /ΔT	I <sub>O</sub> = 5mA		-1.3		mV/°C
Ripple Rejection		RR	f = 120Hz, 18.5V ≤ V <sub>I</sub> ≤ 28.5V, T <sub>J</sub> = 25 °C	34	60		dB
Dropout Voltage		V <sub>D</sub>	T <sub>J</sub> = 25 °C		1.7		V

**LM78L18 ELECTRICAL CHARACTERISTICS**(V<sub>I</sub> = 27V, I<sub>O</sub> = 40mA, 0 °C ≤ T<sub>J</sub> ≤ 125 °C, C<sub>I</sub> = 0.33 μF, C<sub>O</sub> = 0.1 μF, unless otherwise specified. (Note 1))

Characteristic	Symbol	Test Conditions		Min	Typ	Max	Unit
Output Voltage	V <sub>O</sub>	T <sub>J</sub> = 25 °C		17.3	18	18.7	V
Line Regulation	ΔV <sub>O</sub>	T <sub>J</sub> = 25 °C	21V ≤ V <sub>I</sub> ≤ 33V		145	300	mV
			22V ≤ V <sub>I</sub> ≤ 33V		135	250	mV
Load Regulation	ΔV <sub>O</sub>	T <sub>J</sub> = 25 °C	1mA ≤ I <sub>O</sub> ≤ 100mA		30	170	mV
			1mA ≤ I <sub>O</sub> ≤ 40mA		15	85	mV
Output Voltage	V <sub>O</sub>	21V ≤ V <sub>I</sub> ≤ 33V	1mA ≤ I <sub>O</sub> ≤ 40mA	17.1		18.9	V
		21V ≤ V <sub>I</sub> ≤ V <sub>MAX</sub> (Note 2)	1mA ≤ I <sub>O</sub> ≤ 70mA	17.1		18.9	V
Quiescent Current	I <sub>Q</sub>	T <sub>J</sub> = 25 °C			2.2	6.0	mA
Quiescent Current Change	with line	ΔI <sub>Q</sub>	21V ≤ V <sub>I</sub> ≤ 33V			1.5	mA
	with load	ΔI <sub>Q</sub>	1mA ≤ I <sub>O</sub> ≤ 40mA			0.1	mA
Output Noise Voltage	V <sub>N</sub>	T <sub>A</sub> = 25 °C, 10Hz ≤ f ≤ 100KHz			150		μV/V <sub>O</sub>
Temperature Coefficient of V <sub>O</sub>	ΔV <sub>O</sub> /ΔT	I <sub>O</sub> = 5mA			-1.8		mV/°C
Ripple Rejection	RR	f = 120Hz, 23V ≤ V <sub>I</sub> ≤ 33V, T <sub>J</sub> = 25 °C		34	48		dB
Dropout Voltage	V <sub>D</sub>	T <sub>J</sub> = 25 °C			1.7		V

**LM78L24 ELECTRICAL CHARACTERISTICS**(V<sub>I</sub> = 33V, I<sub>O</sub> = 40mA, 0 °C ≤ T<sub>J</sub> ≤ 125 °C, C<sub>I</sub> = 0.33 μF, C<sub>O</sub> = 0.1 μF, unless otherwise specified. (Note 1))

Characteristic	Symbol	Test Conditions		Min	Typ	Max	Unit
Output Voltage	V <sub>O</sub>	T <sub>J</sub> = 25 °C		23	24	25	V
Line Regulation	ΔV <sub>O</sub>	T <sub>J</sub> = 25 °C	27V ≤ V <sub>I</sub> ≤ 38V		160	300	mV
			28V ≤ V <sub>I</sub> ≤ 38V		150	250	mV
Load Regulation	ΔV <sub>O</sub>	T <sub>J</sub> = 25 °C	1mA ≤ I <sub>O</sub> ≤ 100mA		40	200	mV
			1mA ≤ I <sub>O</sub> ≤ 40mA		20	100	mV
Output Voltage	V <sub>O</sub>	27V ≤ V <sub>I</sub> ≤ 38V	1mA ≤ I <sub>O</sub> ≤ 40mA	22.8		25.2	V
		27V ≤ V <sub>I</sub> ≤ V <sub>MAX</sub> (Note 2)	1mA ≤ I <sub>O</sub> ≤ 70mA	22.8		25.2	V
Quiescent Current	I <sub>Q</sub>	T <sub>J</sub> = 25 °C			2.2	6.0	mA
Quiescent Current Change	with line	ΔI <sub>Q</sub>	28V ≤ V <sub>I</sub> ≤ 38V			1.5	mA
	with load	ΔI <sub>Q</sub>	1mA ≤ I <sub>O</sub> ≤ 40mA			0.1	mA
Output Noise Voltage	V <sub>N</sub>	T <sub>A</sub> = 25 °C, 10Hz ≤ f ≤ 100KHz			200		μV/V <sub>O</sub>
Temperature Coefficient of V <sub>O</sub>	ΔV <sub>O</sub> /ΔT	I <sub>O</sub> = 5mA			-2.0		mV/°C
Ripple Rejection	RR	f = 120Hz, 28V ≤ V <sub>I</sub> ≤ 38V, T <sub>J</sub> = 25 °C		34	45		dB
Dropout Voltage	V <sub>D</sub>	T <sub>J</sub> = 25 °C			1.7		V

**Notes**

- The maximum steady state usable output current and input voltage are very dependent on the heat sinking and/or lead length of the package. The data above represent pulse test conditions with junction temperature as indicated at the initiation of tests.
- Power dissipation ≤ 0.75W.

## TYPICAL APPLICATION

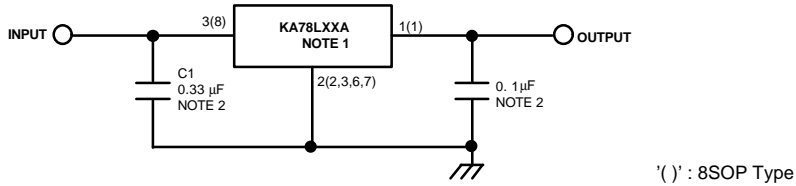

## Notes

1. To specify an output voltage, substitute voltage value for "XX".
2. Bypass Capacitors are recommended for optimum stability and transient response and should be located as close as possible to the regulator.

<http://www.bocasemi.com>

This datasheet has been download from:

[www.datasheetcatalog.com](http://www.datasheetcatalog.com)

Datasheets for electronics components.