

# TYPES SN54H87, SN74H87 4-BIT TRUE/COMPLEMENT, ZERO/ONE ELEMENTS

DECEMBER 1972 REVISED DECEMBER 1983

## description

Operation of these monolithic 4-bit true/complement elements is controlled by the B and C inputs. With the B input low, the 4-bit binary input (A) is transferred to the output (Y) in either complementary form (with C low) or true form (with C high). When the B input is high, the output will be at the complementary level of the C input regardless of the levels of the data inputs.

These circuits are fully compatible for use with other TTL circuits. Input clamping diodes are provided to minimize transmission line effects and thereby simplify system design. Each input represents only one normalized series 54H/74H load, and full fan-out to 10 series 54H/74H loads is available from each of the outputs in the low-level condition.

Power dissipation is 270 mW typically with an average propagation delay of 14 ns from data inputs to output.

The SN54H87 is characterized for operation over the full military temperature range of  $-55^{\circ}\text{C}$  to  $125^{\circ}\text{C}$ , and the SN74H87 is characterized for operation from  $0^{\circ}\text{C}$  to  $70^{\circ}\text{C}$ .

SN54H87 . . . J OR W PACKAGE  
SN74H87 . . . J OR N PACKAGE  
(TOP VIEW)

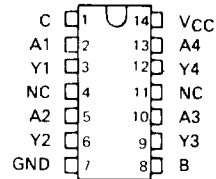

NC No internal connection

FUNCTION TABLE

CONTROL INPUTS		OUTPUTS			
B	C	Y1	Y2	Y3	Y4
L	L	A $\bar{1}$	A $\bar{2}$	A $\bar{3}$	A $\bar{4}$
L	H	A1	A2	A3	A4
H	L	H	H	H	H
H	H	L	L	L	L

H high level, L low level  
A1, A2, A3, A4 the level of the respective A input.

## absolute maximum ratings over operating free-air temperature range (unless otherwise noted)

Supply voltage, $V_{CC}$ (see Note 1)	7 V
Input voltage	5.5 V
Operating free-air temperature range: SN54H87 Circuits	$-55^{\circ}\text{C}$ to $125^{\circ}\text{C}$
SN74H87 Circuits	$0^{\circ}\text{C}$ to $70^{\circ}\text{C}$
Storage temperature range	$-65^{\circ}\text{C}$ to $150^{\circ}\text{C}$

NOTE 1: Voltage values are with respect to network ground terminal.

## recommended operating conditions

	SN54H87			SN74H87			UNIT
	MIN	NOM	MAX	MIN	NOM	MAX	
Supply voltage, $V_{CC}$	4.5	5	5.5	4.75	5	5.25	V
High-level output current, $I_{OH}$			1			1	mA
Low-level output current, $I_{OL}$			20			20	mA
Operating free-air temperature, $T_A$	55		125	0		70	$^{\circ}\text{C}$

3

TTL DEVICES

3-354

**PRODUCTION DATA**  
This document contains information current as of publication date. Products conform to specifications per the terms of Texas Instruments standard warranty. Production processing does not necessarily include testing of all parameters.

TEXAS  
INSTRUMENTS

POST OFFICE BOX 225012 • DALLAS, TEXAS 75265

# TYPES SN54H87, SN74H87

## 4-BIT TRUE/COMPLEMENT, ZERO/ONE ELEMENTS

electrical characteristics over recommended operating free-air temperature range (unless otherwise noted)

PARAMETER	TEST CONDITIONS†	MIN	TYP‡	MAX	UNIT
V <sub>IH</sub> High-level input voltage		2			V
V <sub>IL</sub> Low-level input voltage				0.8	V
V <sub>IK</sub> Input clamp voltage	V <sub>CC</sub> = MIN, I <sub>I</sub> = -8 mA			-1.5	V
V <sub>OH</sub> High-level output voltage	V <sub>CC</sub> = MIN, V <sub>IH</sub> = 2 V, V <sub>IL</sub> = 0.8 V, I <sub>OH</sub> = -1 mA	2.4	3.5		V
V <sub>OL</sub> Low-level output voltage	V <sub>CC</sub> = MIN, V <sub>IH</sub> = 2 V, V <sub>IL</sub> = 0.8 V, I <sub>OL</sub> = 20 mA		0.2	0.4	V
I <sub>I</sub> Input current at maximum input voltage	V <sub>CC</sub> = MAX, V <sub>I</sub> = 5.5 V			1	mA
I <sub>IH</sub> High-level input current	V <sub>CC</sub> = MAX, V <sub>I</sub> = 2.4 V			50	µA
I <sub>IL</sub> Low-level input current	V <sub>CC</sub> = MAX, V <sub>I</sub> = 0.4 V			-2	mA
I <sub>OS</sub> Short-circuit output current§	V <sub>CC</sub> = MAX	-40		-100	mA
I <sub>CC</sub> Supply current	V <sub>CC</sub> = MAX, See Note 2			54	mA
				89	mA

† For conditions shown as MIN or MAX, use the appropriate value specified under recommended operating conditions for the applicable type.

‡ All typical values are at V<sub>CC</sub> = 5 V, T<sub>A</sub> = 25°C.

§ Not more than one output should be shorted at a time and duration of the short-circuit should not exceed 1 second.

NOTE 2: I<sub>CC</sub> is measured for the following conditions:

- a. All A inputs are at 4.5 V, B and C inputs are grounded, and all outputs are open.
- b. B and C inputs are at 4.5 V, all A inputs are grounded, and all outputs are open.

switching characteristics, V<sub>CC</sub> = 5 V, T<sub>A</sub> = 25°C

PARAMETER	TEST CONDITIONS	MIN	TYP	MAX	MAX
t <sub>PLH</sub> Propagation delay time, low-to-high-level output from any A input	C <sub>L</sub> = 25 pF, R <sub>L</sub> = 280 Ω, See Note 3		14	20	ns
t <sub>PHL</sub> Propagation delay time, high-to-low-level output from any A input			13	19	ns
t <sub>PLH</sub> Propagation delay time, low-to-high-level output from B or C inputs			17	25	ns
t <sub>PHL</sub> Propagation delay time, high-to-low-level output from B or C inputs			17	25	ns

NOTE 3: See General Information Section for load circuits and voltage waveforms.

logic diagram

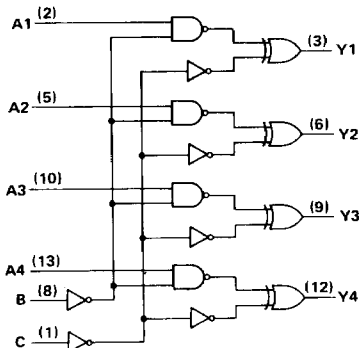

Pin numbers shown on logic notation are for J or N packages.

schematics of inputs and outputs

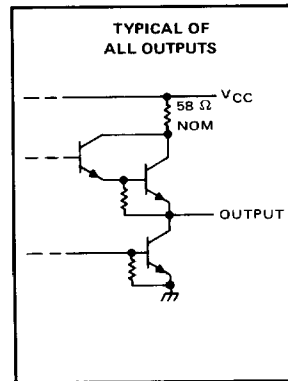
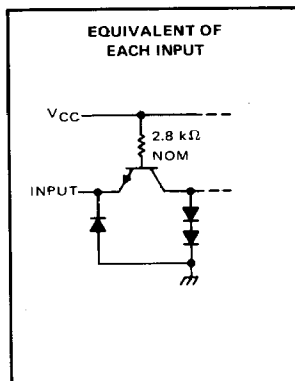

3

TTL DEVICES

**TEXAS**  
**INSTRUMENTS**

POST OFFICE BOX 225012 • DALLAS, TEXAS 75265

3-355

This datasheet has been downloaded from:

[www.DatasheetCatalog.com](http://www.DatasheetCatalog.com)

Datasheets for electronic components.

# Texas Instruments

<http://www.ti.com>

This file is the datasheet for the following electronic components:

SN74H87 - <http://www.ti.com/product/sn74h87?HQS=TI-null-null-dscatalog-df-pf-null-wwe>