

### **+5V Powered RS-232 Transmitters/Receivers**

The HIN230-HIN241 family of RS-232 transmitters/receivers interface circuits meet all EIA RS-232E and V.28 specifications, and are particularly suited for those applications where  $\pm 12V$  is not available. They require a single +5V power supply (except HIN231 and HIN239) and feature onboard charge pump voltage converters which generate +10V and -10V supplies from the 5V supply. The HIN233 and HIN235 require no external capacitors and are ideally suited for applications where circuit board space is critical. The family of devices offer a wide variety of RS-232 transmitter/receiver combinations to accommodate various applications (see Selection Table).

The drivers feature true TTL/CMOS input compatibility, slew-rate-limited output, and 300 $\Omega$  power-off source impedance. The receivers can handle up to  $\pm 30V$ , and have a 3k $\Omega$  to 7k $\Omega$  input impedance. The receivers also feature hysteresis to greatly improve noise rejection.

### **Features**

- Meets All RS-232E and V.28 Specifications
- Requires Only Single +5V Power Supply
  - (+5V and +12V - HIN231 and HIN239)
- High Data Rate . . . . . 120kbps
- HIN233 and HIN235 Require No External Capacitors
- Onboard Voltage Doubler/Inverter
- Low Power Consumption
- Low Power Shutdown Function
- Three-State TTL/CMOS Receiver Outputs
- Multiple Drivers
  - $\pm 10V$  Output Swing for 5V Input
  - 300 $\Omega$  Power-Off Source Impedance
  - Output Current Limiting
  - TTL/CMOS Compatible
  - 30V/ $\mu s$  Maximum Slew Rate
- Multiple Receivers
  - $\pm 30V$  Input Voltage Range
  - 3k $\Omega$  to 7k $\Omega$  Input Impedance
  - 0.5V Hysteresis to Improve Noise Rejection

### **Applications**

- Any System Requiring RS-232 Communication Ports
  - Computer - Portable, Mainframe, Laptop
  - Peripheral - Printers and Terminals
  - Instrumentation
  - Modems

### **Selection Table**

PART NUMBER	POWER SUPPLY VOLTAGE	NUMBER OF RS-232 DRIVERS	NUMBER OF RS-232 RECEIVERS	EXTERNAL COMPONENTS	LOW POWER SHUTDOWN/TTL THREE-STATE	NUMBER OF LEADS
HIN230	+5V	5	0	4 Capacitors	Yes/No	20
HIN231	+5V and +7.5V to 13.2V	2	2	2 Capacitors	No/No	16
HIN232	+5V	2	2	4 Capacitors	No/No	16
HIN233	+5V	2	2	None	No/No	20
HIN234	+5V	4	0	4 Capacitors	No/No	16
HIN235	+5V	5	5	None	Yes/Yes	24
HIN236	+5V	4	3	4 Capacitors	Yes/Yes	24
HIN237	+5V	5	3	4 Capacitors	No/No	24
HIN238	+5V	4	4	4 Capacitors	No/No	24
HIN239	+5V and +7.5V to 13.2V	3	5	2 Capacitors	No/Yes	24
HIN240	+5V	5	5	4 Capacitors	Yes/Yes	44
HIN241	+5V	4	5	4 Capacitors	Yes/Yes	28

## HIN230 thru HIN241

### Ordering Information

PART NUMBER	TEMP. RANGE (°C)	PACKAGE	PKG. NO.
HIN230CB	0 to 70	20 Ld SOIC	M20.3
HIN230IB	-40 to 85	20 Ld SOIC	M20.3
HIN231CB	0 to 70	16 Ld SOIC	M16.3
HIN231CP	0 to 70	14 Ld PDIP	E14.3
HIN231IB	-40 to 85	16 Ld SOIC	M16.3
HIN231IP	-40 to 85	14 Ld PDIP	E14.3
HIN232CP	0 to 70	16 Ld PDIP	E16.3
HIN232CB	0 to 70	16 Ld SOIC	M16.3
HIN232IP	-40 to 85	16 Ld PDIP	E16.3
HIN232IB	-40 to 85	16 Ld SOIC	M16.3
HIN233CP	0 to 70	20 Ld PDIP	E20.3
HIN234CB	0 to 70	16 Ld SOIC	M16.3
HIN234IB	-40 to 85	16 Ld SOIC	M16.3
HIN235CP	0 to 70	24 Ld PDIP	E24.6
HIN236CP	0 to 70	24 Ld PDIP	E24.3
HIN236CB	0 to 70	24 Ld SOIC	M24.3
HIN236IP	-40 to 85	24 Ld PDIP	E24.3
HIN236IB	-40 to 85	24 Ld SOIC	M24.3

PART NUMBER	TEMP. RANGE (°C)	PACKAGE	PKG. NO.
HIN237CP	0 to 70	24 Ld PDIP	E24.3
HIN237CB	0 to 70	24 Ld SOIC	M24.3
HIN237IP	-40 to 85	24 Ld PDIP	E24.3
HIN237IB	-40 to 85	24 Ld SOIC	M24.3
HIN238CP	0 to 70	24 Ld PDIP	E24.3
HIN238CB	0 to 70	24 Ld SOIC	M24.3
HIN238IP	-40 to 85	24 Ld PDIP	E24.3
HIN238IB	-40 to 85	24 Ld SOIC	M24.3
HIN239CB	0 to 70	24 Ld SOIC	M24.3
HIN239CP	0 to 70	24 Ld PDIP	E24.3
HIN239IB	-40 to 85	24 Ld SOIC	M24.3
HIN240CN	0 to 70	44 Ld MQFP	Q44.10X10
HIN240IN	-40 to 85	44 Ld MQFP	Q44.10X10
HIN241CB	0 to 70	28 Ld SOIC	M28.3
HIN241IB	-40 to 85	28 Ld SOIC	M28.3
HIN241CA	0 to 70	28 Ld SSOP	M28.209
HIN241IA	-40 to 85	28 Ld SSOP	M28.209

NOTE: Many of the surface mount devices are available on tape and reel; add -T to suffix.

### Pin Descriptions

PIN	FUNCTION
V <sub>CC</sub>	Power Supply Input 5V ±10%.
V+	Internally generated positive supply (+10V nominal), HIN231 and HIN239 require +7.5V to +13.2V.
V-	Internally generated negative supply (-10V nominal).
GND	Ground lead. Connect to 0V.
C1+	External capacitor (+ terminal) is connected to this lead.
C1-	External capacitor (- terminal) is connected to this lead.
C2+	External capacitor (+ terminal) is connected to this lead.
C2-	External capacitor (- terminal) is connected to this lead.
T <sub>IN</sub>	Transmitter Inputs. These leads accept TTL/CMOS levels. An internal 400kΩ pull-up resistor to V <sub>CC</sub> is connected to each lead.
T <sub>OUT</sub>	Transmitter Outputs. These are RS-232 levels (nominally ±10V).
R <sub>IN</sub>	Receiver Inputs. These inputs accept RS-232 input levels. An internal 5kΩ pull-down resistor to GND is connected to each input.
R <sub>OUT</sub>	Receiver Outputs. These are TTL/CMOS levels.
ĒN	Enable input. This is an active low input which enables the receiver outputs. With ĒN = 5V, the outputs are placed in a high impedance state.
SHUTDOWN	Shutdown Input. With SHUTDOWN = 5V, the charge pump is disabled, the receiver outputs are in a high impedance state and the transmitters are shut off.
NC	No Connect. No connections are made to these leads.

# HIN230 thru HIN241

## Pinouts

HIN230 (SOIC)  
TOP VIEW

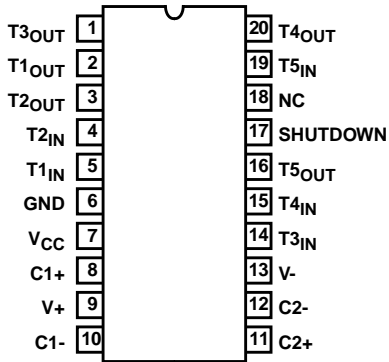

HIN231 (SOIC)  
TOP VIEW

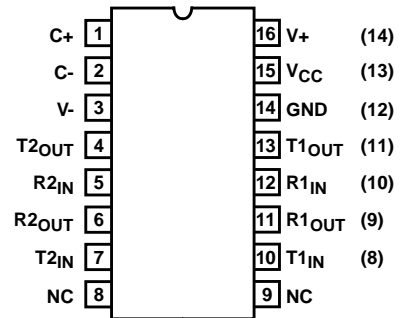

NOTE: Pin numbers in parentheses are for PDIP Package.

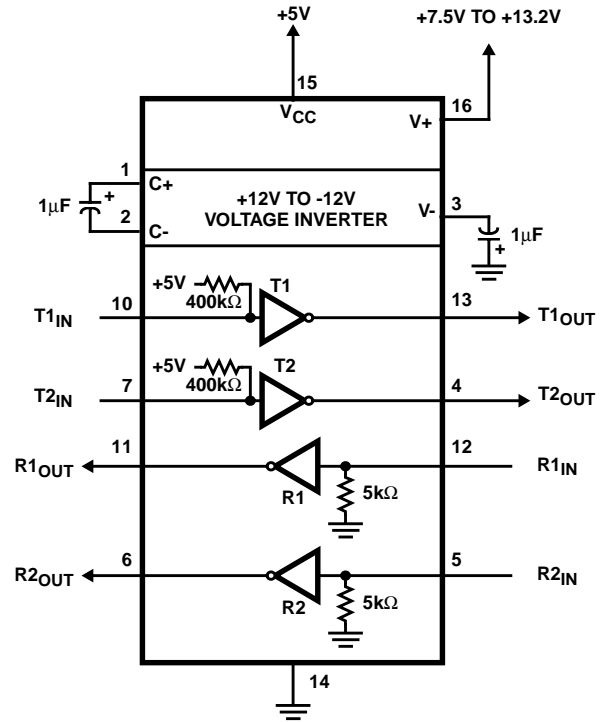
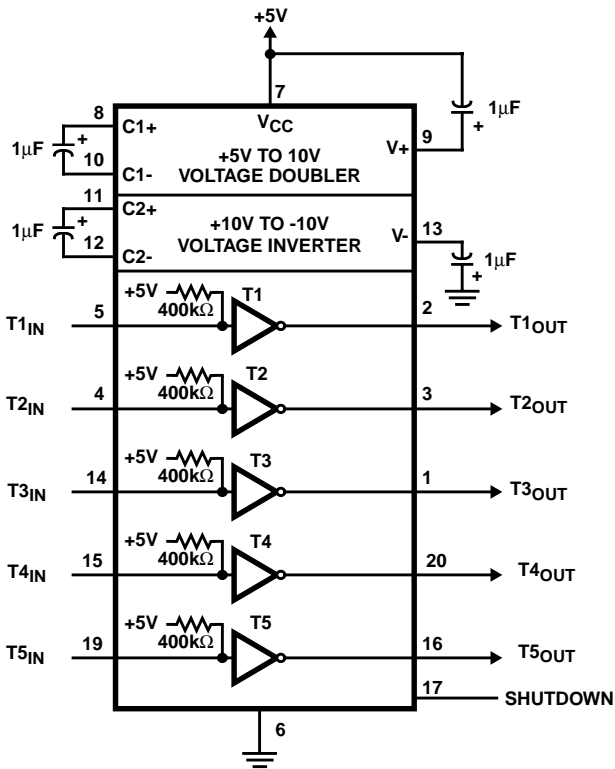

NOTE: SOIC pin numbers shown.

# HIN230 thru HIN241

## Pinouts (Continued)

HIN232 (PDIP, SOIC)  
TOP VIEW

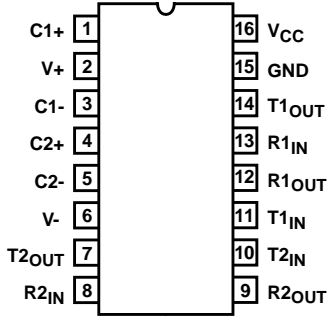

HIN233 (PDIP, SOIC)  
TOP VIEW

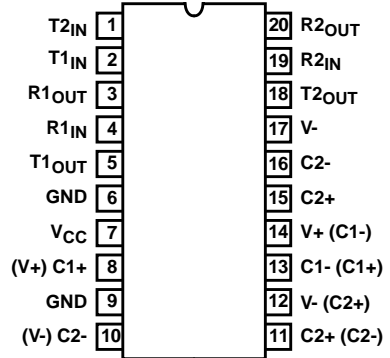

NOTE: Pin names in parentheses are for SOIC Package.

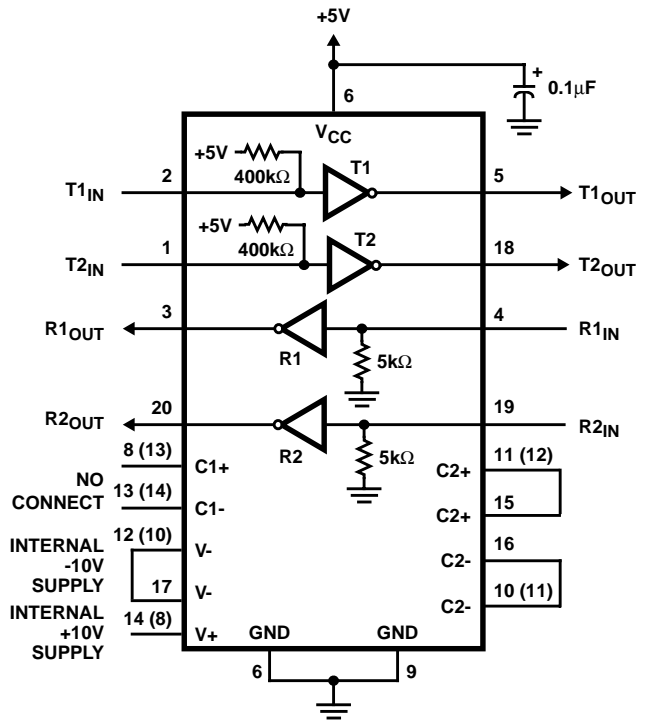
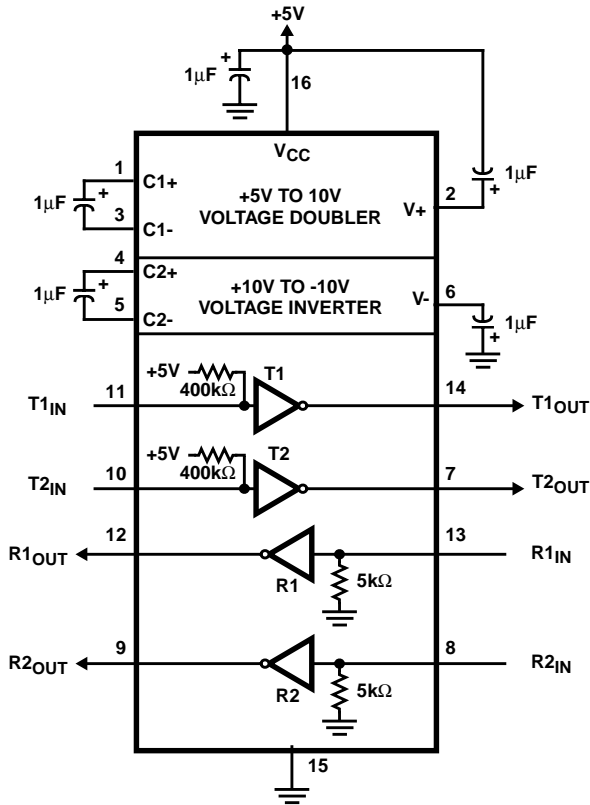

NOTE: Pin numbers in parentheses are for SOIC Package.

# HIN230 thru HIN241

## Pinouts (Continued)

HIN234 (SOIC)  
TOP VIEW

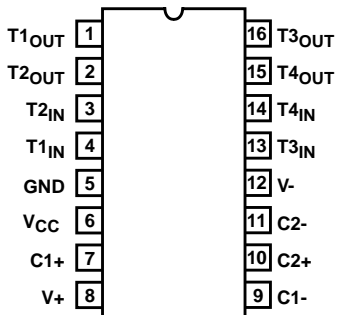

HIN235 (PDIP)  
TOP VIEW

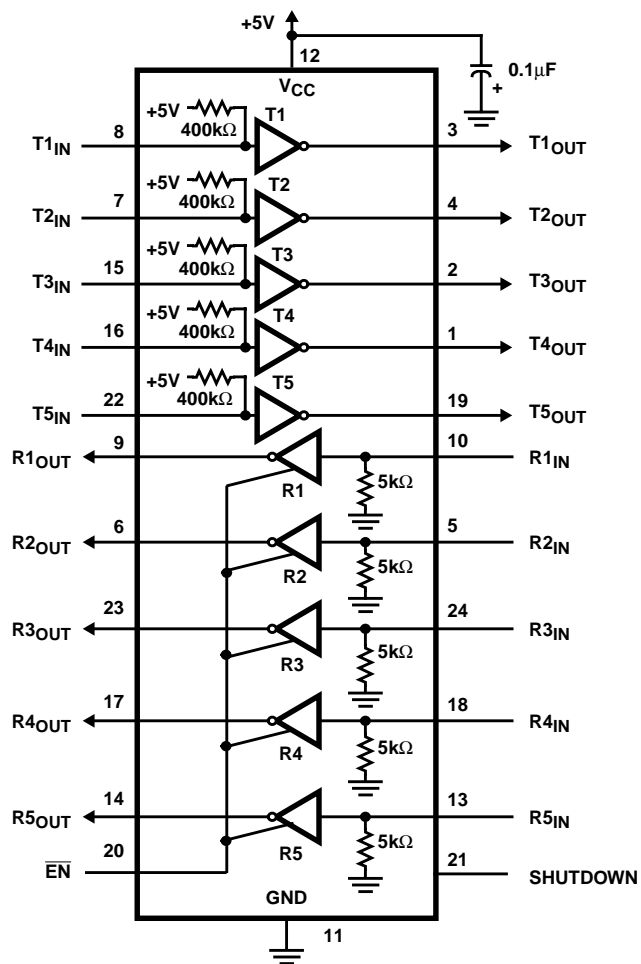
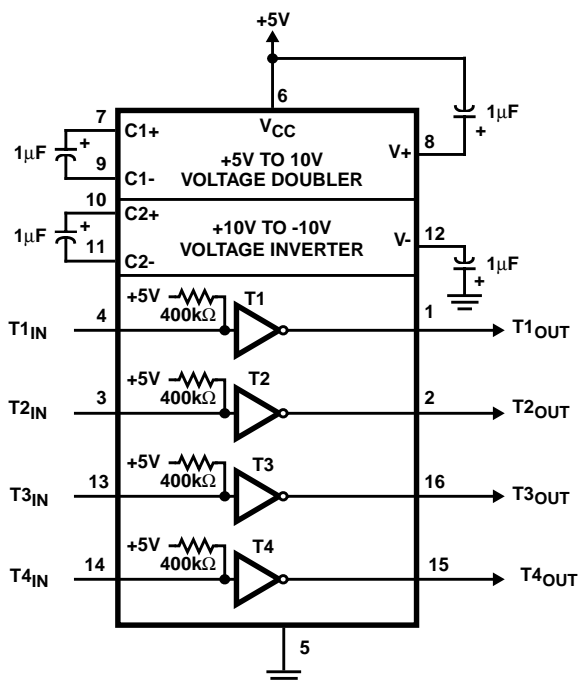
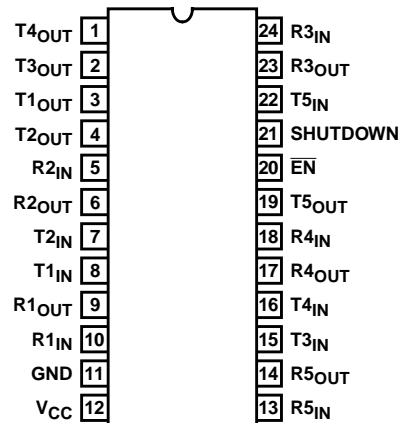

# HIN230 thru HIN241

## Pinouts (Continued)

**HIN236 (PDIP, SOIC)**  
TOP VIEW

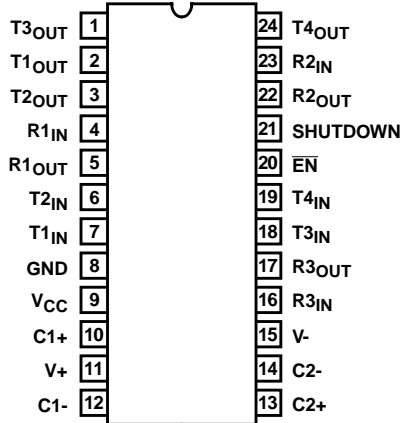

**HIN237 (PDIP, SOIC)**  
TOP VIEW

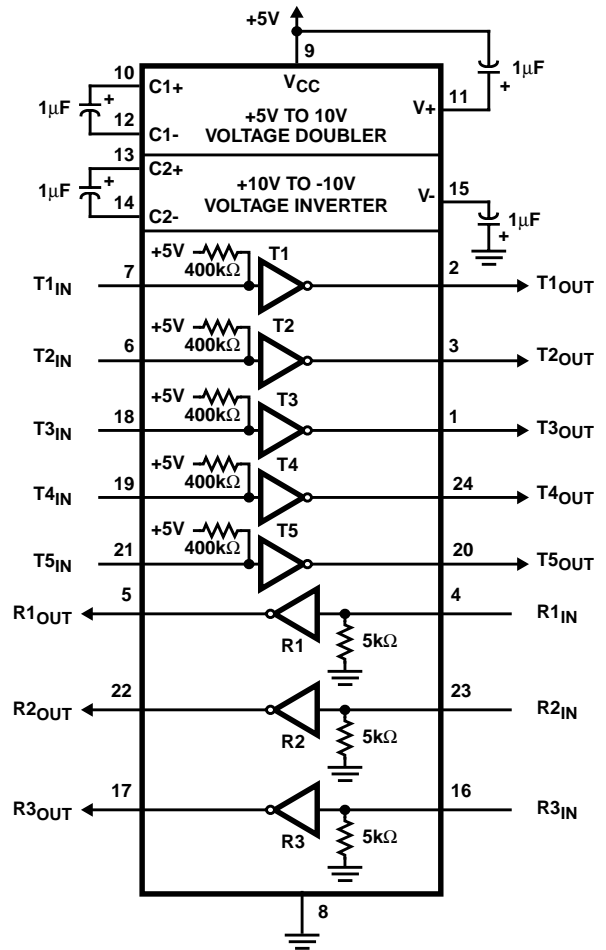
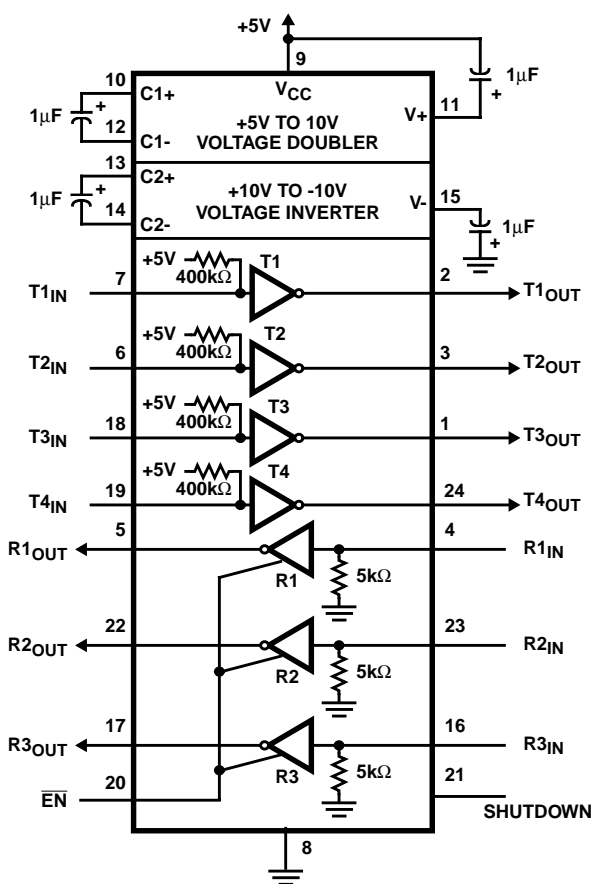
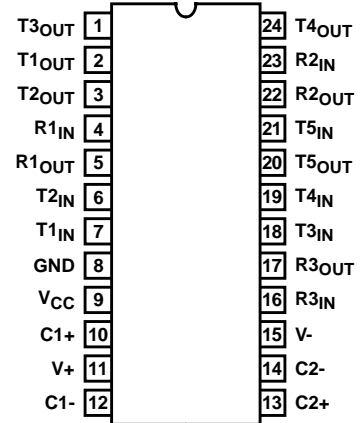

# HIN230 thru HIN241

## Pinouts (Continued)

HIN238 (PDIP, SOIC)  
TOP VIEW

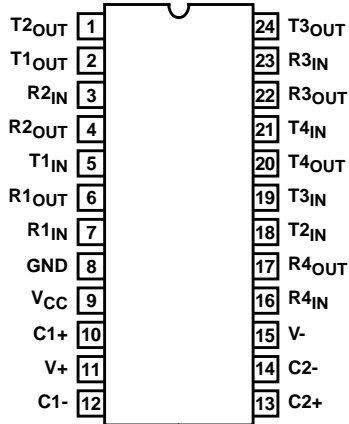

HIN239 (SOIC)  
TOP VIEW

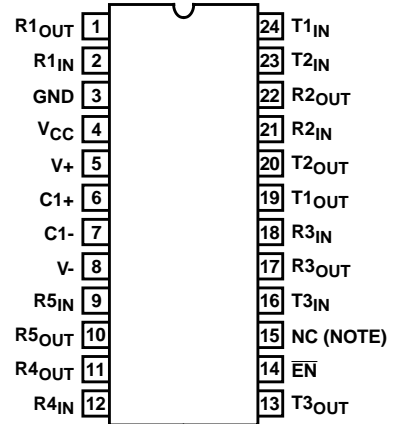

NOTE: No Connect

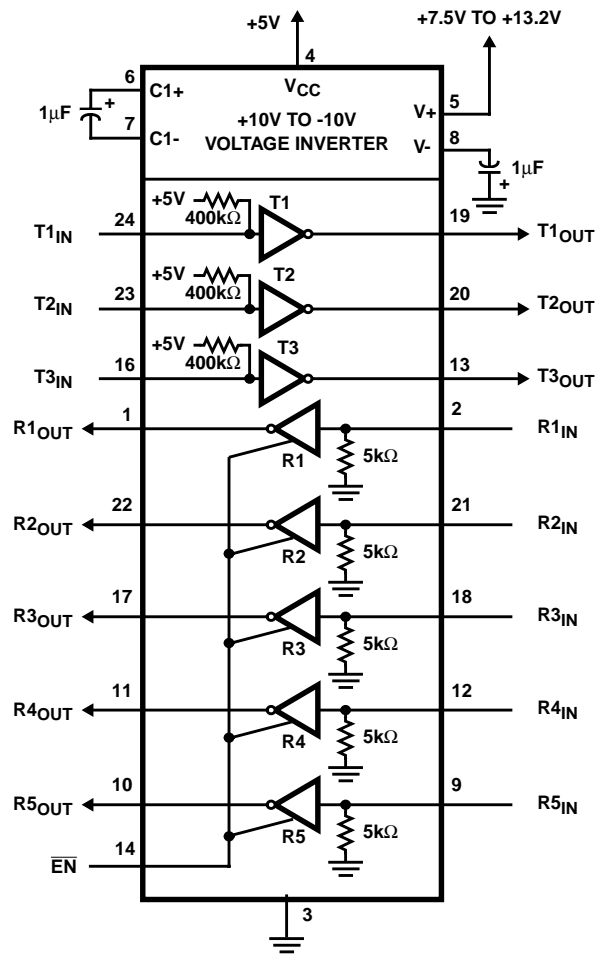
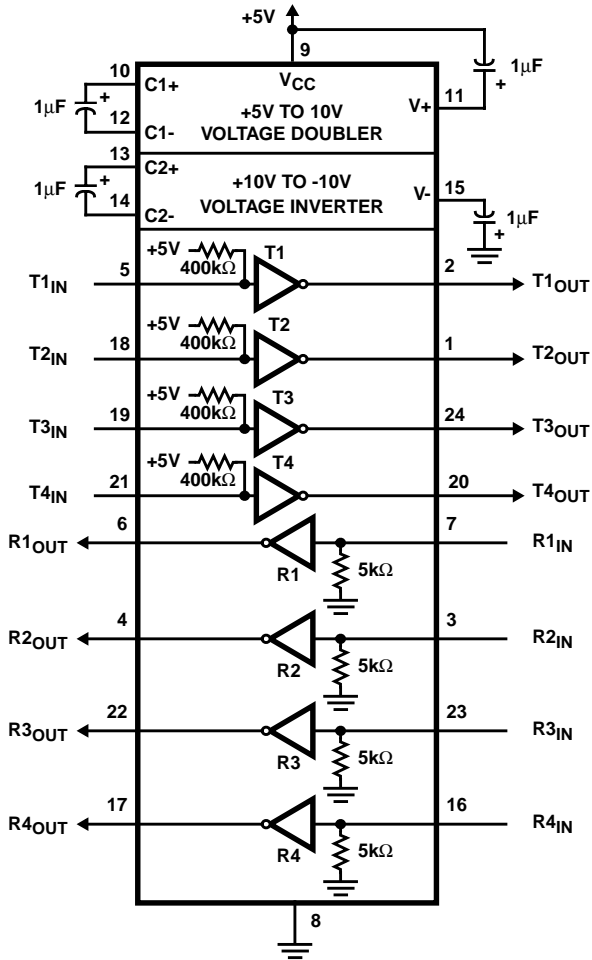

# HIN230 thru HIN241

## Pinouts (Continued)

HIN240 (MQFP)

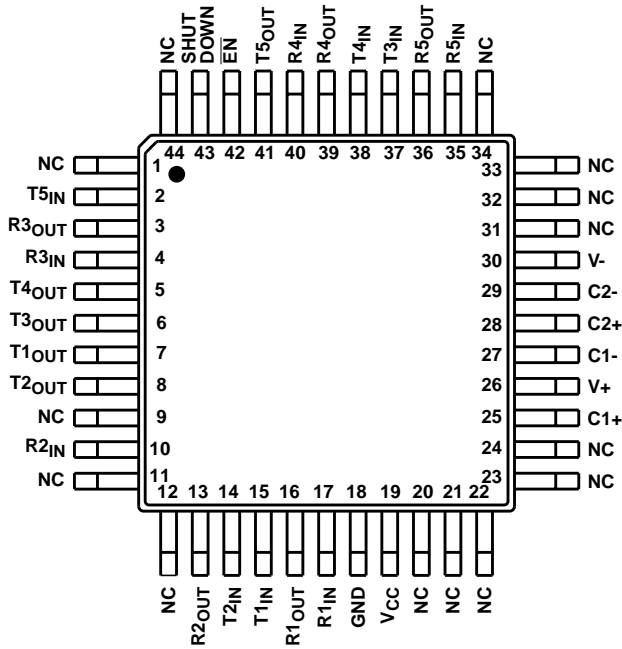

HIN241 (SOIC, SSOP)  
TOP VIEW

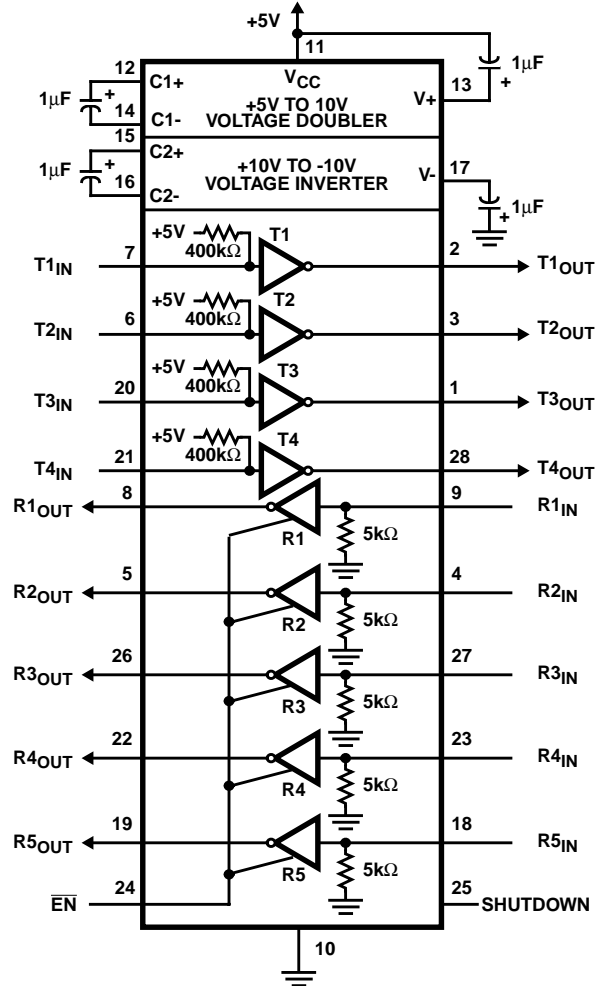
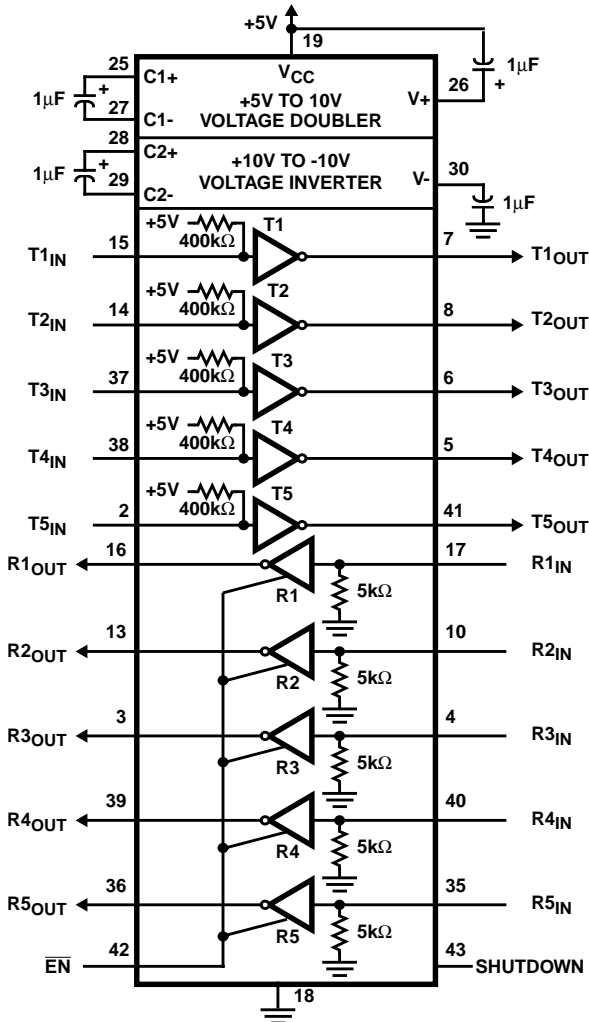
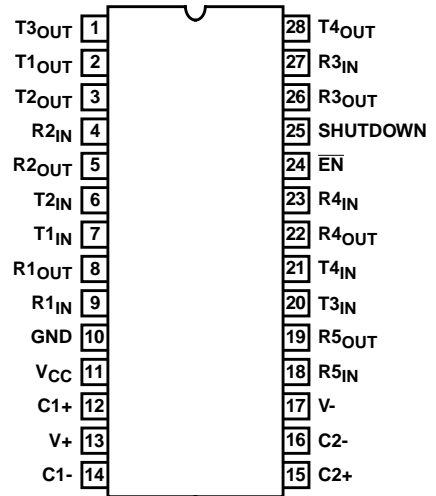



# HIN230 thru HIN241

## Absolute Maximum Ratings

$V_{CC}$ to Ground	$(GND - 0.3V) < V_{CC} < 6V$
$V+$ to Ground	$(V_{CC} - 0.3V) < V+ < 12V$
$V-$ to Ground	$-12V < V- < (GND + 0.3V)$
Input Voltages	
$T_{IN}$	$(V- - 0.3V) < V_{IN} < (V+ + 0.3V)$
$R_{IN}$	$\pm 30V$
Output Voltages	
$T_{OUT}$	$(V- - 0.3V) < V_{TXOUT} < (V+ + 0.3V)$
$R_{OUT}$	$(GND - 0.3V) < V_{RXOUT} < (V+ + 0.3V)$
Short Circuit Duration	
$T_{OUT}$	Continuous
$R_{OUT}$	Continuous

## Operating Conditions

Temperature Range	
HIN2XXCX	$0^{\circ}C$ to $70^{\circ}C$
HIN2XXIX	$-40^{\circ}C$ to $85^{\circ}C$

## Thermal Information

Thermal Resistance (Typical, Note 1)	$\theta_{JA}$ ( $^{\circ}C/W$ )
14 Ld PDIP Package	90
16 Ld PDIP Package	90
20 Ld PDIP Package	80
24 Ld PDIP Package	70
16 Ld SOIC (W) Package	100
20 Ld SOIC Package	120
24 Ld SOIC Package	75
28 Ld SOIC Package	70
28 Ld SSOP Package	95
44 Ld MQFP Package	80
Maximum Junction Temperature (Plastic Package)	$150^{\circ}C$
Maximum Storage Temperature Range	$-65^{\circ}C$ to $150^{\circ}C$
Maximum Lead Temperature (Soldering 10s)	$300^{\circ}C$ (SOIC, SSOP, MQFP - Lead Tips Only)

**CAUTION:** Stresses above those listed in "Absolute Maximum Ratings" may cause permanent damage to the device. This is a stress only rating and operation of the device at these or any other conditions above those indicated in the operational sections of this specification is not implied.

### NOTE:

- $\theta_{JA}$  is measured with the component mounted on an evaluation PC board in free air.

## Electrical Specifications Test Conditions: $V_{CC} = +5V \pm 10\%$ , $T_A =$ Operating Temperature Range

PARAMETER	TEST CONDITIONS	MIN	TYP	MAX	UNITS	
<b>SUPPLY CURRENTS</b>						
Power Supply Current, $I_{CC}$	No Load, $T_A = 25^{\circ}C$	HIN232-233	-	5	10	mA
		HIN230, HIN234-238, HIN240-241	-	7	15	mA
		HIN231, HIN239	-	0.4	1	mA
$V+$ Power Supply Current, $I_{CC}$ No Load, $T_A = 25^{\circ}C$	No Load, $T_A = 25^{\circ}C$	HIN231	-	1.8	5	mA
		HIN239	-	5.0	15	mA
Shutdown Supply Current, $I_{CC}(SD)$	$T_A = 25^{\circ}C$	-	1	10	$\mu A$	
<b>LOGIC AND TRANSMITTER INPUTS, RECEIVER OUTPUTS</b>						
Input Logic Low, $V_{IL}$	$T_{IN}, \overline{EN}$ , Shutdown	-	-	0.8	V	
Input Logic High, $V_{IH}$	$T_{IN}$	2.0	-	-	V	
	$\overline{EN}$ , Shutdown	2.4	-	-	V	
Transmitter Input Pullup Current, $I_P$	$T_{IN} = 0V$	-	15	200	$\mu A$	
TTL/CMOS Receiver Output Voltage Low, $V_{OL}$	$I_{OUT} = 1.6mA$ (HIN231-HIN233 $I_{OUT} = 3.2mA$ )	-	0.1	0.4	V	
TTL/CMOS Receiver Output Voltage High, $V_{OH}$	$I_{OUT} = -1.0mA$	3.5	4.6	-	V	
<b>RECEIVER INPUTS</b>						
RS-232 Input Voltage Range $V_{IN}$		-30	-	+30	V	
Receiver Input Impedance $R_{IN}$	$V_{IN} = \pm 3V$	3.0	5.0	7.0	k $\Omega$	
Receiver Input Low Threshold, $V_{IN}$ (H-L)	$V_{CC} = 5V, T_A = 25^{\circ}C$	0.8	1.2	-	V	
Receiver Input High Threshold, $V_{IN}$ (L-H)	$V_{CC} = 5V, T_A = 25^{\circ}C$	-	1.7	2.4	V	
Receiver Input Hysteresis $V_{HYST}$		0.2	0.5	1.0	V	
<b>TIMING CHARACTERISTICS</b>						
Baud Rate (1 Transmitter Switching)	$R_L = 3k\Omega$	120	-	-	kbps	
Output Enable Time, $t_{EN}$	HIN235, 236, 239, 240, 241	-	400	-	ns	
Output Disable Time, $t_{DIS}$	HIN235, 236, 239, 240, 241	-	250	-	ns	

## HIN230 thru HIN241

### Electrical Specifications Test Conditions: $V_{CC} = +5V \pm 10\%$ , $T_A =$ Operating Temperature Range (Continued)

PARAMETER	TEST CONDITIONS	MIN	TYP	MAX	UNITS
Propagation Delay, $t_{PD}$	RS-232 to TTL	-	0.5	-	$\mu s$
Instantaneous Slew Rate SR	$C_L = 10pF$ , $R_L = 3k\Omega$ , $T_A = 25^\circ C$ (Note 2)	-	-	30	$V/\mu s$
Transition Region Slew Rate, $SR_T$	$R_L = 3k\Omega$ , $C_L = 2500pF$ Measured from +3V to -3V or -3V to +3V, 1 Transmitter Switching	-	3	-	$V/\mu s$
<b>TRANSMITTER OUTPUTS</b>					
Output Voltage Swing, $T_{OUT}$	Transmitter Outputs, $3k\Omega$ to Ground	$\pm 5$	$\pm 9$	$\pm 10$	V
Output Resistance, $R_{OUT}$	$V_{CC} = V_+ = V_- = 0V$ , $V_{OUT} = \pm 2V$	300	-	-	$\Omega$
RS-232 Output Short Circuit Current, $I_{SC}$	$T_{OUT}$ shorted to GND	-	$\pm 10$	-	mA

NOTE:

2. Guaranteed by design.

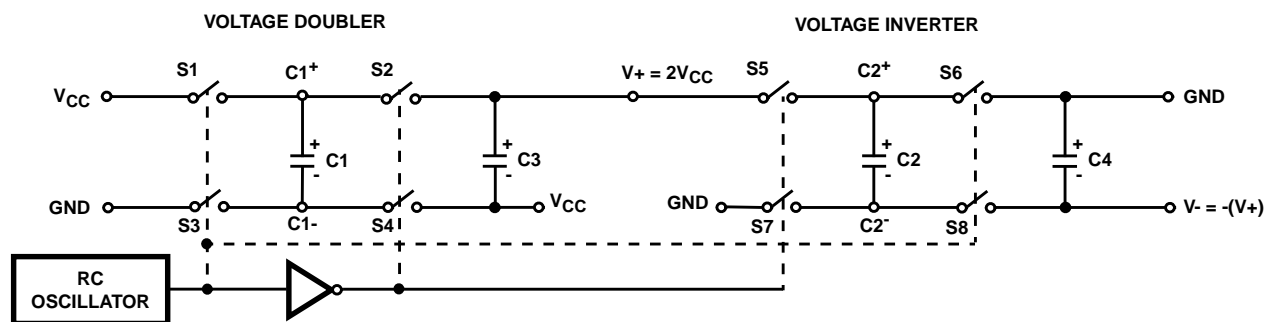

FIGURE 1. CHARGE PUMP

### Detailed Description

The HIN230 thru HIN241 family of RS-232 transmitters/receivers are powered by a single +5V power supply (except HIN231 and HIN239), feature low power consumption, and meet all EIA RS-232C and V.28 specifications. The circuit is divided into three sections: The charge pump, transmitter, and receiver.

### Charge Pump

An equivalent circuit of the charge pump is illustrated in Figure 1. The charge pump contains two sections: the voltage doubler and the voltage inverter. Each section is driven by a two phase, internally generated clock to generate +10V and -10V. The nominal clock frequency is 16kHz. During phase one of the clock, capacitor C1 is charged to  $V_{CC}$ . During phase two, the voltage on C1 is added to  $V_{CC}$ , producing a signal across C3 equal to twice  $V_{CC}$ . During phase one, C2 is also charged to  $2V_{CC}$ , and then during phase two, it is inverted with respect to ground to produce a signal across C4 equal to  $-2V_{CC}$ . The charge pump accepts input voltages up to 5.5V. The output impedance of the voltage doubler section ( $V+$ ) is approximately  $200\Omega$ , and the output impedance of the voltage inverter section ( $V-$ ) is approximately  $450\Omega$ . A typical application uses  $1\mu F$  capacitors for C1-C4, however, the value is not critical. Increasing the values of C1 and C2 will lower the output impedance of the voltage doubler and inverter, increasing the values of the reservoir capacitors, C3 and C4, lowers the ripple on the  $V+$  and  $V-$  supplies.

During shutdown mode (HIN230, 235, 236, 240 and 241), SHUTDOWN control line set to logic "1", the charge pump is turned off,  $V+$  is pulled down to  $V_{CC}$ ,  $V-$  is pulled up to GND, and the supply current is reduced to less than  $10\mu A$ . The transmitter outputs are disabled and the receiver outputs are placed in the high impedance state.

### Transmitters

The transmitters are TTL/CMOS compatible inverters which translate the inputs to RS-232 outputs. The input logic threshold is about 26% of  $V_{CC}$ , or 1.3V for  $V_{CC} = 5V$ . A logic 1 at the input results in a voltage of between -5V and  $V-$  at the output, and a logic 0 results in a voltage between +5V and ( $V+ - 0.6V$ ). Each transmitter input has an internal  $400k\Omega$  pullup

resistor so any unused input can be left unconnected and its output remains in its low state. The output voltage swing meets the RS-232C specifications of  $\pm 5V$  minimum with the worst case conditions of: all transmitters driving  $3k\Omega$  minimum load impedance,  $V_{CC} = 4.5V$ , and maximum allowable operating temperature. The transmitters have an internally limited output slew rate which is less than  $30V/\mu s$ . The outputs are short circuit protected and can be shorted to ground indefinitely. The powered down output impedance is a minimum of  $300\Omega$  with  $\pm 2V$  applied to the outputs and  $V_{CC} = 0V$ .

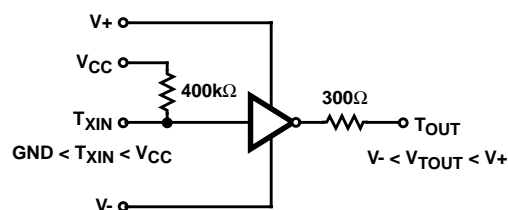

FIGURE 2. TRANSMITTER

### Receivers

The receiver inputs accept up to  $\pm 30V$  while presenting the required  $3k\Omega$  to  $7k\Omega$  input impedance even if the power is off ( $V_{CC} = 0V$ ). The receivers have a typical input threshold of 1.3V which is within the  $\pm 3V$  limits, known as the transition region, of the RS-232 specifications. The receiver output is 0V to  $V_{CC}$ . The output will be low whenever the input is greater than 2.4V and high whenever the input is floating or driven between +0.8V and -30V. The receivers feature 0.5V hysteresis to improve noise rejection. The receiver Enable line  $\overline{EN}$ , when set to logic "1", (HIN235, 236, 239, 240, and 241) disables the receiver outputs, placing them in the high impedance mode. The receiver outputs are also placed in the high impedance state when in shutdown mode.

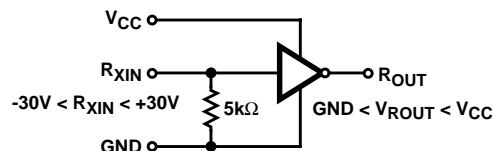

FIGURE 3. RECEIVER

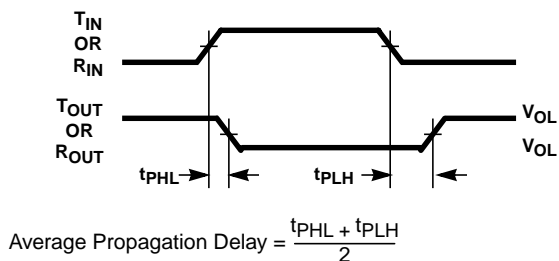

FIGURE 4. PROPAGATION DELAY DEFINITION

Typical Performance Curves

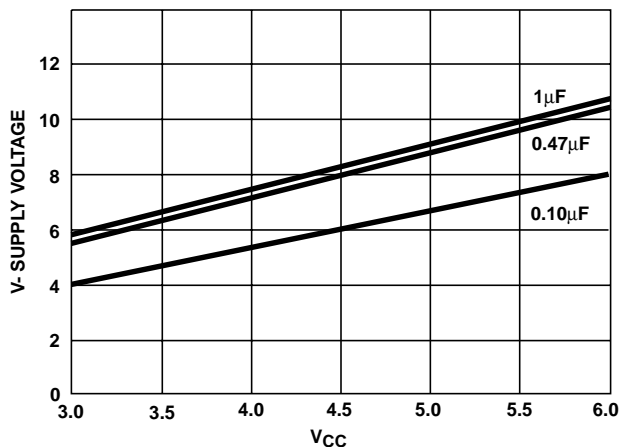

FIGURE 5. V- SUPPLY VOLTAGE vs V<sub>CC</sub>, VARYING CAPACITORS

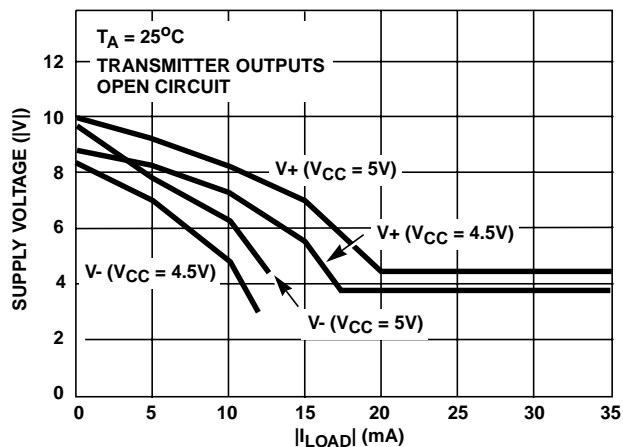

FIGURE 6. V<sub>+</sub>, V<sub>-</sub> OUTPUT VOLTAGE vs LOAD (HIN232)

Test Circuits (HIN232)

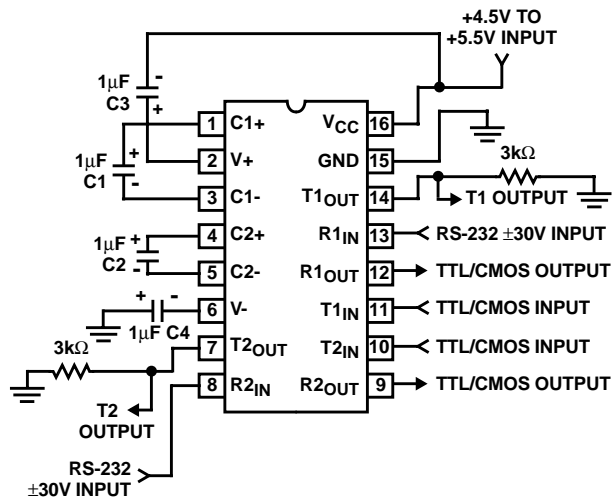

FIGURE 7. GENERAL TEST CIRCUIT

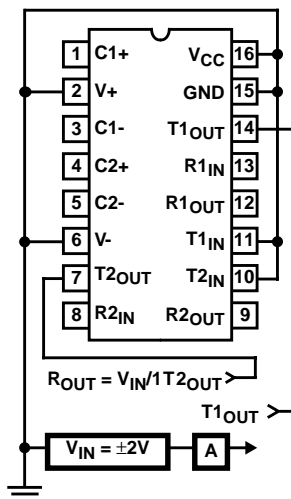

FIGURE 8. POWER-OFF SOURCE RESISTANCE CONFIGURATION

**Applications**

The HIN2XX may be used for all RS-232 data terminal and communication links. It is particularly useful in applications where  $\pm 12V$  power supplies are not available for conventional RS-232 interface circuits. The applications presented represent typical interface configurations.

A simple duplex RS-232 port with CTS/RTS handshaking is illustrated in Figure 9. Fixed output signals such as DTR (data terminal ready) and DSRS (data signaling rate select) is generated by driving them through a  $5k\Omega$  resistor connected to  $V+$ .

In applications requiring four RS-232 inputs and outputs (Figure 10), note that each circuit requires two charge pump capacitors ( $C1$  and  $C2$ ) but can share common reservoir capacitors ( $C3$  and  $C4$ ). The benefit of sharing common reservoir capacitors is the elimination of two capacitors and the reduction of the charge pump source impedance which effectively increases the output swing of the transmitters.

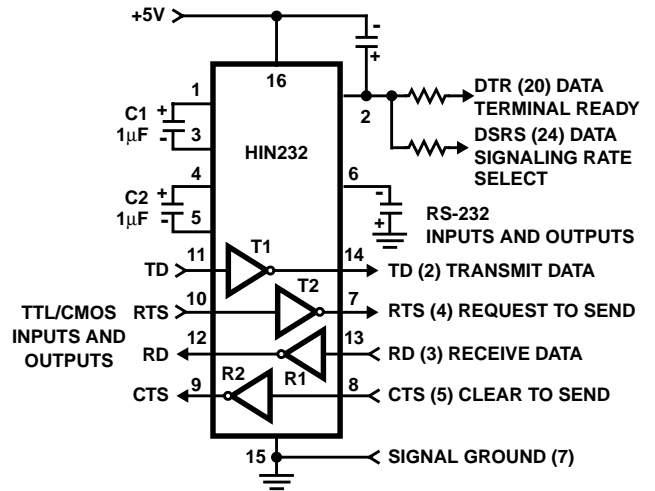

FIGURE 9. SIMPLE DUPLEX RS-232 PORT WITH CTS/RTS HANDSHAKING

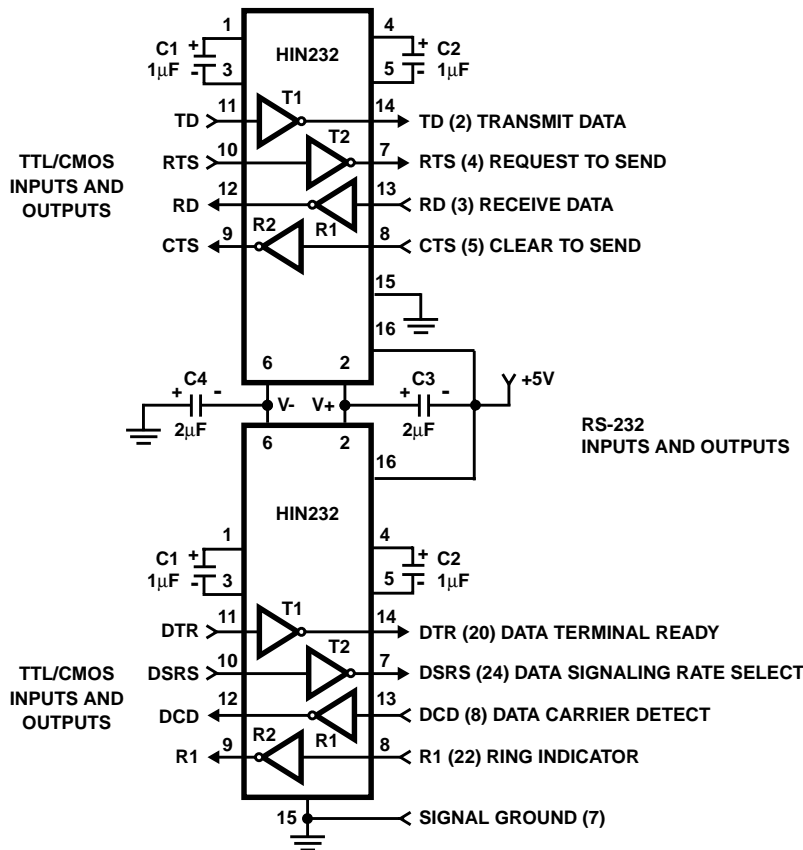

FIGURE 10. COMBINING TWO HIN232s FOR 4 PAIRS OF RS-232 INPUTS AND OUTPUTS

# HIN230 thru HIN241

## Die Characteristics

### DIE DIMENSIONS:

160 mils x 140 mils

### METALLIZATION:

Type: Al

Thickness:  $10k\text{\AA} \pm 1k\text{\AA}$

### SUBSTRATE POTENTIAL

V+

### PASSIVATION:

Type: Nitride over Silox

Nitride Thickness:  $8k\text{\AA}$

Silox Thickness:  $7k\text{\AA}$

### TRANSISTOR COUNT:

238

### PROCESS:

CMOS Metal Gate

## Metallization Mask Layout

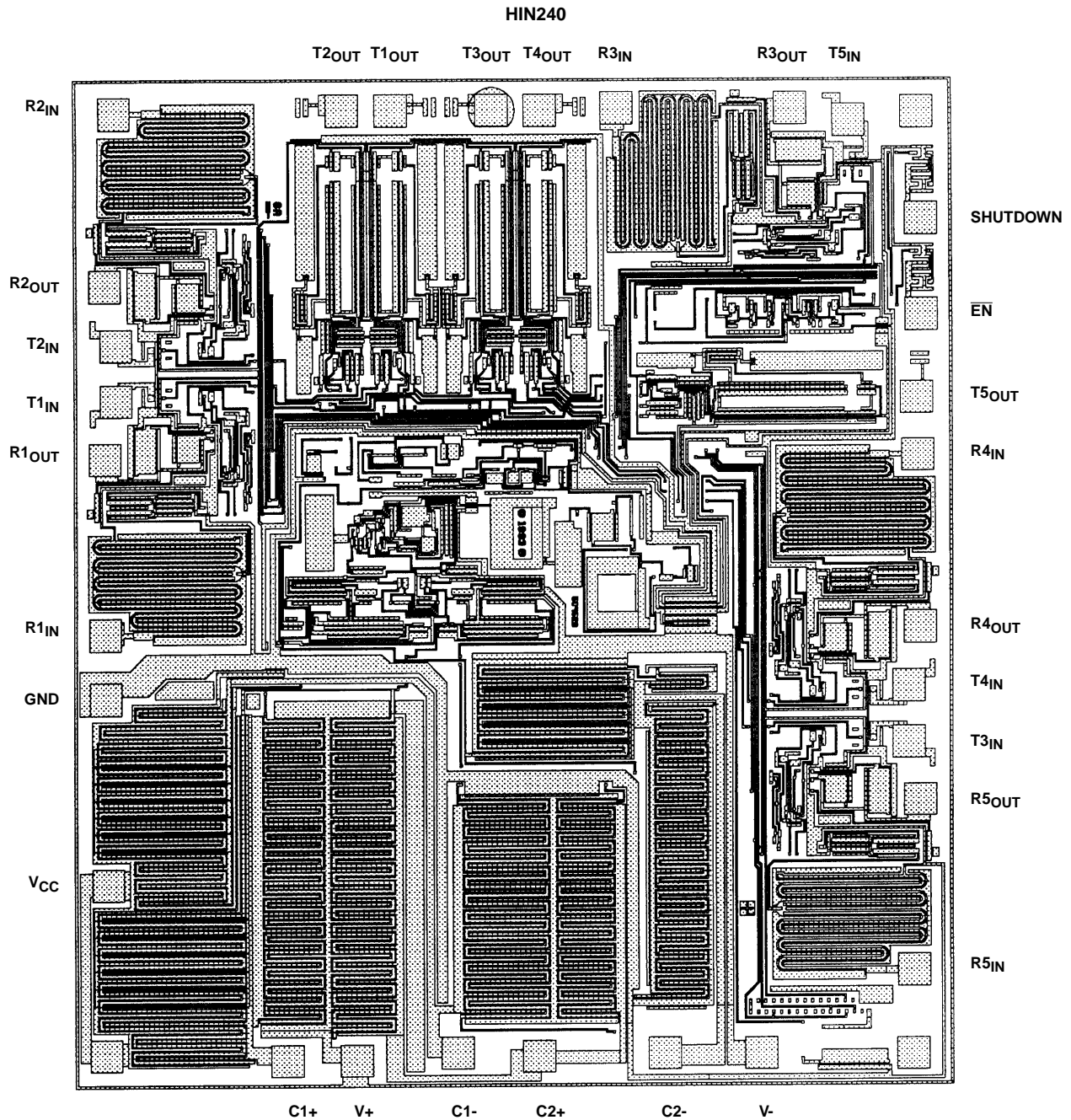

All Intersil semiconductor products are manufactured, assembled and tested under **ISO9000** quality systems certification.

*Intersil semiconductor products are sold by description only. Intersil Corporation reserves the right to make changes in circuit design and/or specifications at any time without notice. Accordingly, the reader is cautioned to verify that data sheets are current before placing orders. Information furnished by Intersil is believed to be accurate and reliable. However, no responsibility is assumed by Intersil or its subsidiaries for its use; nor for any infringements of patents or other rights of third parties which may result from its use. No license is granted by implication or otherwise under any patent or patent rights of Intersil or its subsidiaries.*

For information regarding Intersil Corporation and its products, see web site **www.intersil.com**

### **Sales Office Headquarters**

#### **NORTH AMERICA**

Intersil Corporation  
P. O. Box 883, Mail Stop 53-204  
Melbourne, FL 32902  
TEL: (321) 724-7000  
FAX: (321) 724-7240

#### **EUROPE**

Intersil SA  
Mercure Center  
100, Rue de la Fusee  
1130 Brussels, Belgium  
TEL: (32) 2.724.2111  
FAX: (32) 2.724.22.05

#### **ASIA**

Intersil (Taiwan) Ltd.  
7F-6, No. 101 Fu Hsing North Road  
Taipei, Taiwan  
Republic of China  
TEL: (886) 2 2716 9310  
FAX: (886) 2 2715 3029

This datasheet has been downloaded from:

[www.DatasheetCatalog.com](http://www.DatasheetCatalog.com)

Datasheets for electronic components.