

54F/74F160A • 74F162A Synchronous Presettable BCD Decade Counter

General Description

The 'F160A and 'F162A are high-speed synchronous decade counters operating in the BCD (8421) sequence. They are synchronously presettable for applications in programmable dividers. There are two types of Count Enable inputs plus a Terminal Count output for versatility in forming synchronous multistage counters. The 'F160A has an asynchronous Master Reset input that overrides all other inputs and forces the outputs LOW. The 'F162A has a Synchronous Reset input that overrides counting and parallel load-

ing and allows all outputs to be simultaneously reset on the rising edge of the clock. The 'F160A and 'F162A are high speed versions of the 'F160 and 'F162.

Features

- Synchronous counting and loading
- High-speed synchronous expansion
- Typical count rate of 120 MHz
- Guaranteed 4000V minimum ESD protection

Commercial	Military	Package Number	Package Description
74F160APC		N16E	16-Lead (0.300" Wide) Molded Dual-in-Line
	54F160ADM (Note 2)	J16A	16-Lead Ceramic Dual-in-Line
74F160ASC (Note 1)		M16A	16-Lead (0.150" Wide) Molded Small Outline, JEDEC
74F160ASJ (Note 1)		M16D	16-Lead (0.300" Wide) Molded Small Outline, EIAJ
	54F160AFM (Note 2)	W16A	16-Lead Cerpack
	54F160ALM (Note 2)	E20A	20-Lead Ceramic Leadless Chip Carrier, Type C
74F162APC		N16E	16-Lead (0.300" Wide) Molded Dual-In-Line
74F162ASC (Note 1)		M16A	16-Lead (0.150" Wide) Molded Small Outline, JEDEC
74F162ASJ (Note 1)		M16D	16-Lead (0.300" Wide) Molded Small Outline, EIAJ

Note 1: Devices also available in 13" reel. Use suffix = SCX and SJX.

Note 2: Military grade device with environmental and burn-in processing. Use suffix = DMOB, FMOB and LMOB.

Connection Diagrams

Pin Assignment for DIP, SOIC and Flatpak

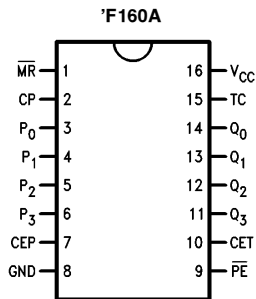

TL/F/9485-1

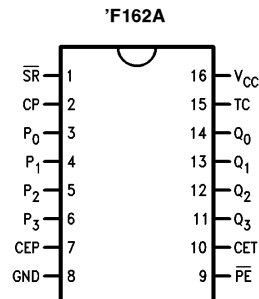

TL/F/9485-9

TRI-STATE® is a registered trademark of National Semiconductor Corporation.

Logic Symbols

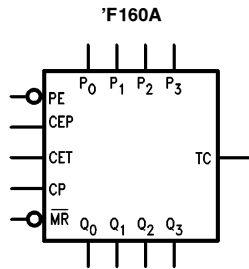

TL/F/9485-3

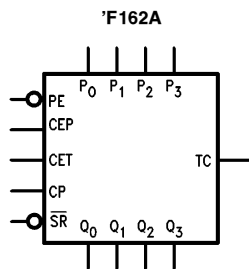

TL/F/9485-8

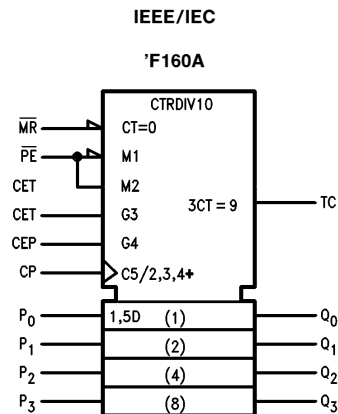

TL/F/9485-6

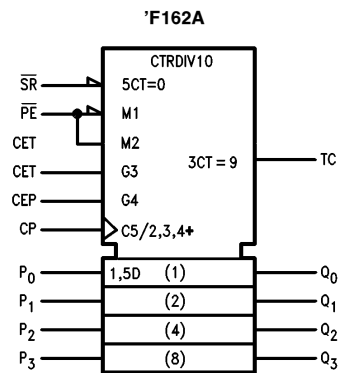

TL/F/9485-7

Unit Loading/Fan Out

Pin Names	Description	54F/74F	
		U.L. HIGH/LOW	Input I_H/I_{IL} Output I_{OH}/I_{OL}
CEP	Count Enable Parallel Input	1.0/1.0	20 μ A/ -0.6 mA
CET	Count Enable Trickle Input	1.0/2.0	20 μ A/ -1.2 mA
CP	Clock Pulse Input (Active Rising Edge)	1.0/1.0	20 μ A/ -0.6 mA
\overline{MR} ('F160A)	Asynchronous Master Reset Input (Active LOW)	1.0/1.0	20 μ A/ -0.6 mA
\overline{SR} ('F162A)	Synchronous Reset Input (Active LOW)	1.0/2.0	20 μ A/ -1.2 mA
P ₀ -P ₃	Parallel Data Inputs	1.0/1.0	20 μ A/ -0.6 mA
PE	Parallel Enable Input (Active LOW)	1.0/2.0	20 μ A/ -1.2 mA
Q ₀ -Q ₃	Flip-Flop Outputs	50/33.3	-1 mA/20 mA
TC	Terminal Count Output	50/33.3	-1 mA/20 mA

Functional Description

The 'F160A and 'F162A count modulo-10 in the BCD (8421) sequence. From state 9 (HLLH) they increment to state 0 (LLLL). The clock inputs of all flip-flops are driven in parallel through a clock buffer. Thus all changes of the Q outputs (except due to Master Reset of the ('F160A) occur as a result of, and synchronous with, the LOW-to-HIGH transition of the CP input signal. The circuits have four fundamental modes of operation, in order of precedence: asynchronous reset ('F160A), synchronous reset ('F162A), parallel load, count-up and hold. Five control inputs—Master Reset (\overline{MR} , 'F160A), Synchronous Reset (\overline{SR} , 'F162A), Parallel Enable (\overline{PE}), Count Enable Parallel (CEP) and Count Enable Trickle (CET)—determine the mode of operation, as shown in the Mode Select Table. A LOW signal on \overline{MR} overrides all other inputs and asynchronously forces all outputs LOW. A LOW signal on \overline{SR} overrides counting and parallel loading and allows all outputs to go LOW on the next rising edge of CP. A LOW signal on \overline{PE} overrides counting and allows information on the Parallel Data (P_n) inputs to be loaded into the flip-flops on the next rising edge of CP. With \overline{PE} and \overline{MR} ('F160A) or \overline{SR} ('F162A) HIGH, CEP and CET permit counting when both are HIGH. Conversely, a LOW signal on either CEP or CET inhibits counting.

The 'F160A and 'F162A use D-type edge-triggered flip-flops and changing the \overline{SR} , \overline{PE} , CEP and CET inputs when the CP is in either state does not cause errors, provided that the recommended setup and hold times, with respect to the rising edge of CP, are observed.

The Terminal Count (TC) output is HIGH when CET is HIGH and counter is in state 9. To implement synchronous multi-stage counters, the TC outputs can be used with the CEP and CET inputs in two different ways. Please refer to the 'F568 data sheet. The TC output is subject to decoding spikes due to internal race conditions and is therefore not recommended for use as a clock or asynchronous reset for flip-flops, counters or registers. In the 'F160A and 'F162A decade counters, the TC output is fully decoded and can only be HIGH in state 9. If a decade counter is preset to an illegal state, or assumes an illegal state when power is applied, it will return to the normal sequence within two counts, as shown in the State Diagram.

Logic Equations:

$$\text{Count Enable} = \text{CEP} \times \text{CET} \times \overline{PE}$$

$$\text{TC} = Q_0 \times \overline{Q_1} \times \overline{Q_2} \times Q_3 \times \text{CET}$$

Mode Select Table

* \overline{SR}	\overline{PE}	CET	CEP	Action on the Rising Clock Edge (\nearrow)
L	X	X	X	Reset (Clear)
H	L	X	X	Load ($P_n \rightarrow Q_n$)
H	H	H	H	Count (Increment)
H	H	L	X	No Change (Hold)
H	H	X	L	No Change (Hold)

*For 'F162A only
H = HIGH Voltage Level
L = LOW Voltage Level
X = Immaterial

State Diagram

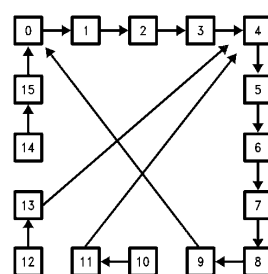

TL/F/9485-4

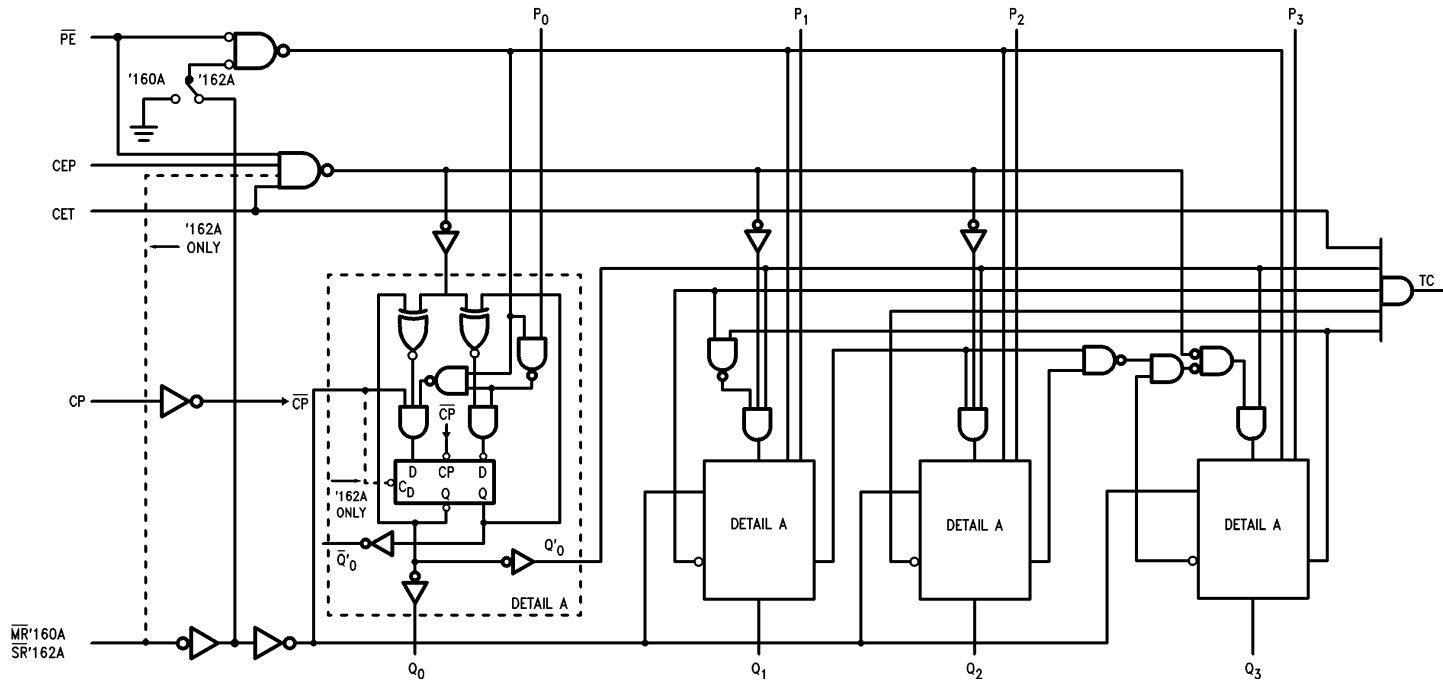

4

Please note that this diagram is provided only for the understanding of logic operations and should not be used to estimate propagation delays.

Absolute Maximum Ratings (Note 1)

If Military/Aerospace specified devices are required, please contact the National Semiconductor Sales Office/Distributors for availability and specifications.

Storage Temperature	-65°C to +150°C
Ambient Temperature under Bias	-55°C to +125°C
Junction Temperature under Bias	-55°C to +175°C
Plastic	-55°C to +150°C
V _{CC} Pin Potential to Ground Pin	-0.5V to +7.0V
Input Voltage (Note 2)	-0.5V to +7.0V
Input Current (Note 2)	-30 mA to +5.0 mA
Voltage Applied to Output in HIGH State (with V _{CC} = 0V)	
Standard Output	-0.5V to V _{CC}
TRI-STATE® Output	-0.5V to +5.5V
Current Applied to Output in LOW State (Max)	twice the rated I _{OL} (mA)
ESD Last Passing Voltage (Min)	4000V

Note 1: Absolute maximum ratings are values beyond which the device may be damaged or have its useful life impaired. Functional operation under these conditions is not implied.

Note 2: Either voltage limit or current limit is sufficient to protect inputs.

Recommended Operating Conditions

Free Air Ambient Temperature	
Military	-55°C to +125°C
Commercial	0°C to +70°C
Supply Voltage	
Military	+4.5V to +5.5V
Commercial	+4.5V to +5.5V

DC Electrical Characteristics

Symbol	Parameter	54F/74F			Units	V _{CC}	Conditions
		Min	Typ	Max			
V _{IH}	Input HIGH Voltage	2.0			V		Recognized as a HIGH Signal
V _{IL}	Input LOW Voltage			0.8	V		Recognized as a LOW Signal
V _{CD}	Input Clamp Diode Voltage			-1.2	V	Min	I _{IN} = -18 mA
V _{OH}	Output HIGH Voltage	54F 10% V _{CC} 74F 10% V _{CC} 74F 5% V _{CC}	2.5 2.5 2.7		V	Min	I _{OH} = -1 mA I _{OH} = -1 mA I _{OH} = -1 mA
V _{OL}	Output LOW Voltage	54F 10% V _{CC} 74F 10% V _{CC}		0.5 0.5	V	Min	I _{OL} = 20 mA I _{OL} = 20 mA
I _{IH}	Input HIGH Current	54F 74F		20.0 5.0	μA	Max	V _{IN} = 2.7V
I _{BVI}	Input HIGH Current Breakdown Test	54F 74F		100 7.0	μA	Max	V _{IN} = 7.0V
I _{CEX}	Output HIGH Leakage Current	54F 74F		250 50	μA	Max	V _{OUT} = V _{CC}
V _{ID}	Input Leakage Test	74F	4.75		V	0.0	I _{ID} = 1.9 μA All Other Pins Grounded
I _{OD}	Output Leakage Circuit Current	74F		3.75	μA	0.0	V _{IOD} = 150 mV All Other Pins Grounded
I _{IL}	Input LOW Current			-0.6 -1.2	mA mA	Max Max	V _{IN} = 0.5V (CP, CEP, P _n , \overline{MR} ('F160A)) V _{IN} = 0.5V (CET, \overline{SR} ('F162A), \overline{PE})
I _{OS}	Output Short-Circuit Current			-60 -150	mA	Max	V _{OUT} = 0V
I _{CC}	Power Supply Current			37 55	mA	Max	V _O = HIGH

AC Electrical Characteristics

Symbol	Parameter	74F			54F		74F		Units
		T _A = +25°C V _{CC} = +5.0V C _L = 50 pF			T _A , V _{CC} = Mil C _L = 50 pF		T _A , V _{CC} = Com C _L = 50 pF		
		Min	Typ	Max	Min	Max	Min	Max	
f _{max}	Maximum Count Frequency	90	120		75		80		MHz
t _{PLH} t _{PHL}	Propagation Delay, Count CP to Q _n (\overline{PE} Input HIGH)	3.5 3.5	5.5 7.5	7.5 10.0	3.5 3.5	9.0 11.5	3.5 3.5	8.5 11.0	ns
t _{PLH} t _{PHL}	Propagation Delay, Load CP to Q _n (\overline{PE} Input LOW)	4.0 4.0	6.0 6.0	8.5 8.5	4.0 4.0	10.0 10.0	4.0 4.0	9.5 9.5	ns
t _{PLH} t _{PHL}	Propagation Delay CP to TC	5.0 5.0	10.0 10.0	14.0 14.0	5.0 5.0	16.5 15.5	5.0 5.0	15.0 15.0	ns
t _{PLH} t _{PHL}	Propagation Delay CET to TC	2.5 2.5	4.5 4.5	7.5 7.5	2.5 2.5	9.0 9.0	2.5 2.5	8.5 8.5	ns
t _{PHL}	Propagation Delay \overline{MR} to Q _n ('F160A)	5.5	9.0	12.0	5.5	14.0	5.5	13.0	ns
t _{PHL}	Propagation Delay \overline{MR} to TC ('F160A)	4.5	8.0	10.5	4.5	12.5	4.5	11.5	ns

AC Operating Requirements

Symbol	Parameter	74F		54F		74F		Units
		$T_A = +25^\circ\text{C}$ $V_{CC} = +5.0\text{V}$		$T_A, V_{CC} = \text{Mil}$		$T_A, V_{CC} = \text{Com}$		
		Min	Max	Min	Max	Min	Max	
$t_s(\text{H})$ $t_s(\text{L})$	Setup Time, HIGH or LOW P_n to CP ('F160A)	4.0 5.0		5.5 5.5		4.0 5.0		ns
$t_s(\text{H})$ $t_s(\text{L})$	Setup Time, HIGH or LOW P_n to CP ('F162A)	5.0 5.0				5.0 5.0		ns
$t_h(\text{H})$ $t_h(\text{L})$	Hold Time, HIGH or LOW P_n to CP	2.0 2.0		2.5 2.5		2.0 2.0		ns
$t_s(\text{H})$ $t_s(\text{L})$	Setup Time, HIGH or LOW $\overline{\text{PE}}$ or $\overline{\text{SR}}$ to CP	11.0 8.5		13.5 10.5		11.5 9.5		ns
$t_h(\text{H})$ $t_h(\text{L})$	Hold Time, HIGH or LOW $\overline{\text{PE}}$ or $\overline{\text{SR}}$ to CP	2.0 0		2.0 0		2.0 0		ns
$t_s(\text{H})$ $t_s(\text{L})$	Setup Time, HIGH or LOW CEP or CET to CP	11.0 5.0		13.0 6.0		11.5 5.0		ns
$t_h(\text{H})$ $t_h(\text{L})$	Hold Time, HIGH or LOW CEP or CET to CP	0 0		0 0		0 0		ns
$t_w(\text{H})$ $t_w(\text{L})$	Clock Pulse Width (Load) HIGH or LOW	5.0 5.0		5.0 5.0		5.0 5.0		ns
$t_w(\text{H})$ $t_w(\text{L})$	Clock Pulse Width (Count) HIGH or LOW	4.0 6.0		5.0 8.0		4.0 7.0		ns
$t_w(\text{L})$	$\overline{\text{MR}}$ Pulse Width, LOW ('F160A)	5.0		5.0		5.0		ns
t_{rec}	Recovery Time $\overline{\text{MR}}$ to CP ('F160A)	6.0		6.0		6.0		ns

Ordering Information

The device number is used to form part of a simplified purchasing code where the package type and temperature range are defined as follows:

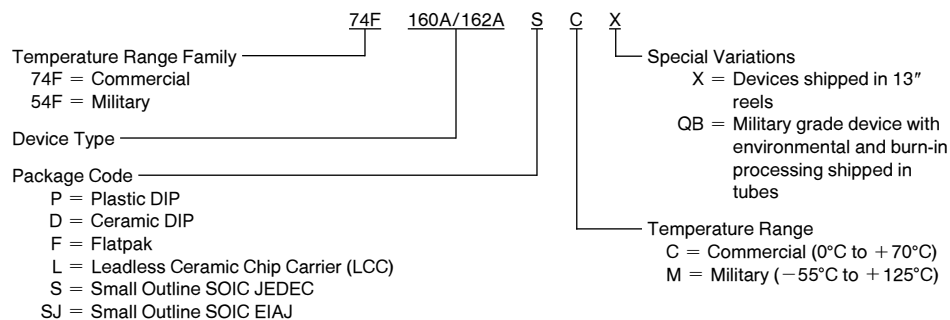

Physical Dimensions inches (millimeters)

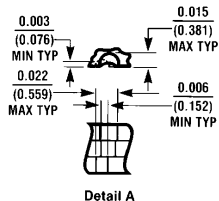
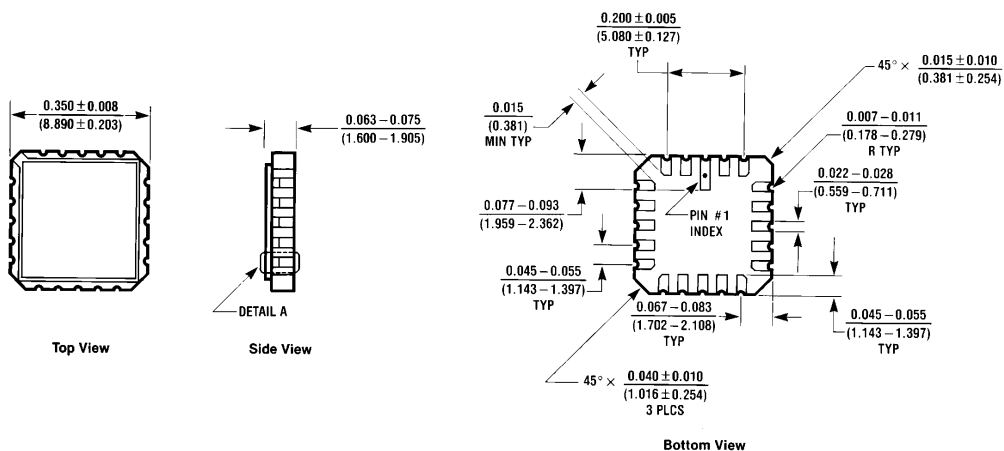

20-Lead Ceramic Leadless Chip Carrier (L)
NS Package Number E20A

E20A (REV D)

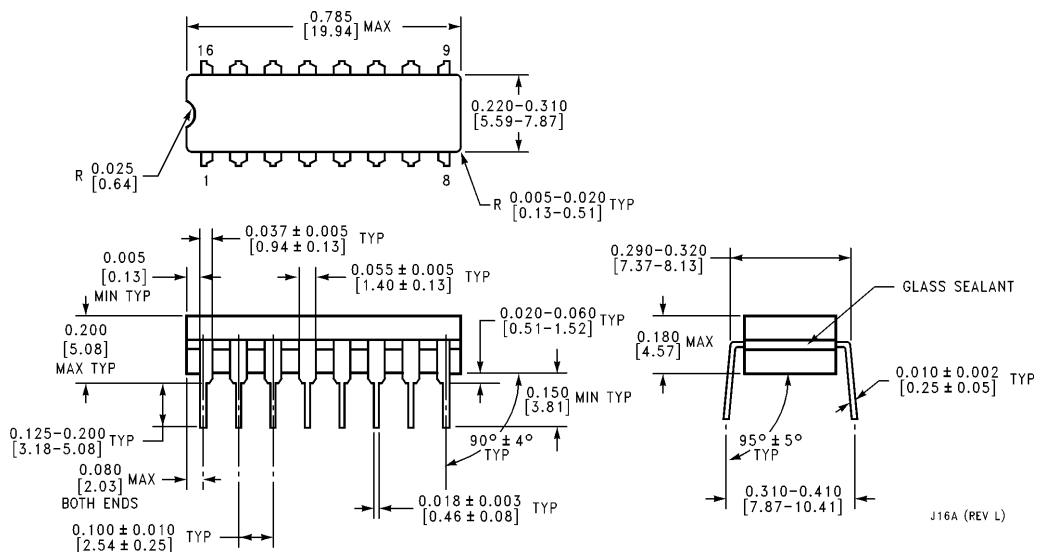

16 Lead Ceramic Dual-In-Line Package (D)
NS Package Number J16A

J16A (REV L)

Physical Dimensions inches (millimeters) (Continued)

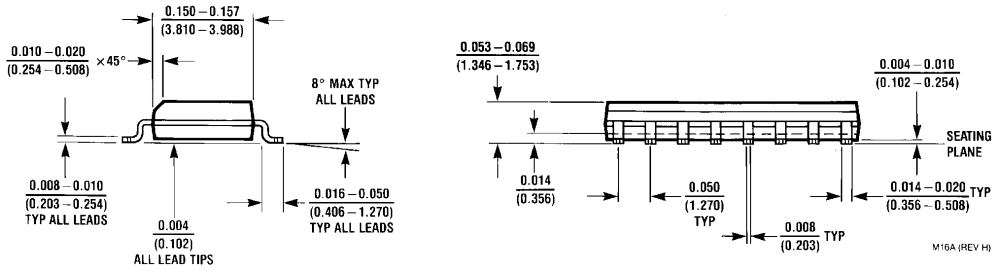
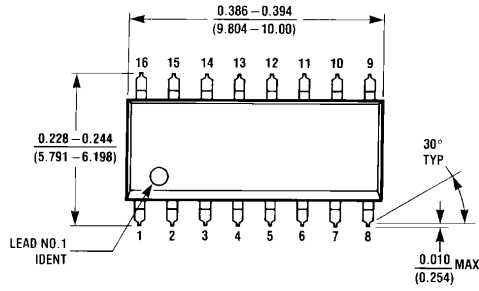

16-Lead (0.150" Wide) Molded Small Outline Package, JEDEC (S)
NS Package Number M16A

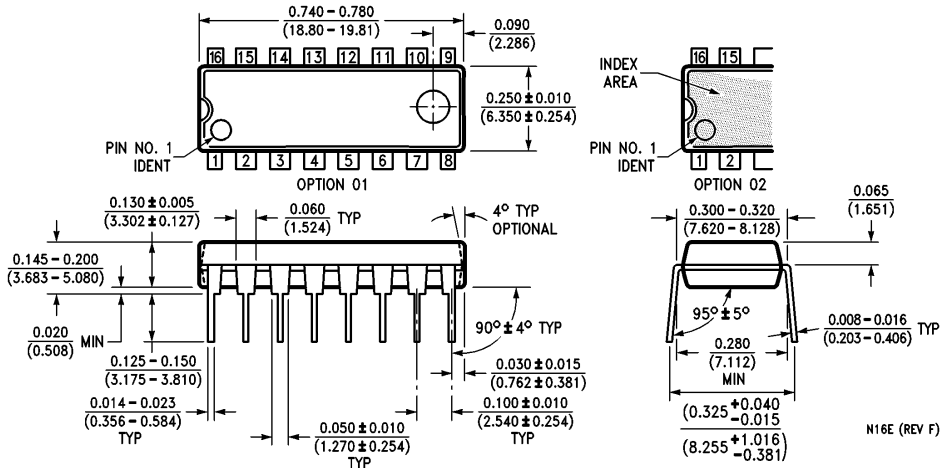

16-Lead (0.300" Wide) Molded Dual-In-Line Package (P)
NS Package Number N16E

Physical Dimensions inches (millimeters) (Continued)

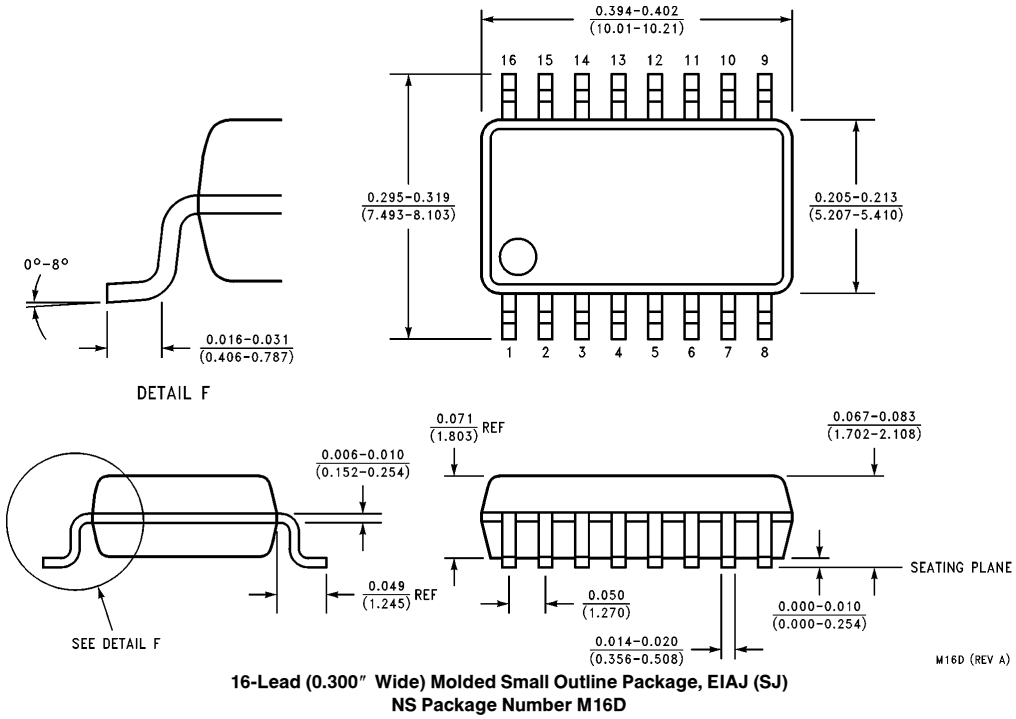

Physical Dimensions inches (millimeters) (Continued)

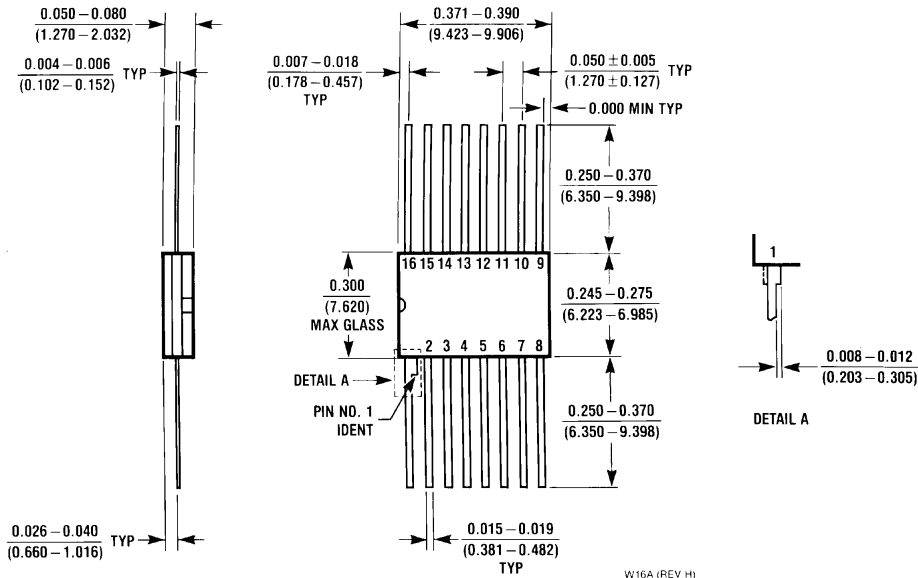

**16 Lead Ceramic Flatpak (F)
NS Package Number W16A**

LIFE SUPPORT POLICY

NATIONAL'S PRODUCTS ARE NOT AUTHORIZED FOR USE AS CRITICAL COMPONENTS IN LIFE SUPPORT DEVICES OR SYSTEMS WITHOUT THE EXPRESS WRITTEN APPROVAL OF THE PRESIDENT OF NATIONAL SEMICONDUCTOR CORPORATION. As used herein:

1. Life support devices or systems are devices or systems which, (a) are intended for surgical implant into the body, or (b) support or sustain life, and whose failure to perform, when properly used in accordance with instructions for use provided in the labeling, can be reasonably expected to result in a significant injury to the user.
2. A critical component is any component of a life support device or system whose failure to perform can be reasonably expected to cause the failure of the life support device or system, or to affect its safety or effectiveness.



National Semiconductor Corporation
2900 Semiconductor Drive
P.O. Box 58090
Santa Clara, CA 95052-8090
Tel: 1(800) 272-9959
TWX: (910) 339-9240

National Semiconductor GmbH
Livry-Gargan-Str. 10
D-82256 Fürstenfeldbruck
Germany
Tel: (81-41) 35-0
Telex: 527849
Fax: (81-41) 35-1

National Semiconductor Japan Ltd.
Sumitomo Chemical
Engineering Center
Bldg. 7F
1-7-1, Nakase, Mihama-Ku
Chiba-City,
Ciba Prefecture 261
Tel: (043) 299-2300
Fax: (043) 299-2500

National Semiconductor Hong Kong Ltd.
13th Floor, Straight Block,
Ocean Centre, 5 Canton Rd.
Tsimshatsui, Kowloon
Hong Kong
Tel: (852) 2737-1600
Fax: (852) 2736-9960

National Semicondutores Do Brazil Ltda.
Rue Deputado Lacorda Franco
120-3A
Sao Paulo-SP
Brazil 05418-000
Tel: (55-11) 212-5066
Telex: 391-1131931 NSBR BR
Fax: (55-11) 212-1181

National Semiconductor (Australia) Pty. Ltd.
Building 16
Business Park Drive
Monash Business Park
Nottingham, Melbourne
Victoria 3168 Australia
Tel: (3) 558-9999
Fax: (3) 558-9998

National does not assume any responsibility for use of any circuitry described, no circuit patent licenses are implied and National reserves the right at any time without notice to change said circuitry and specifications.

This datasheet has been download from:

www.datasheetcatalog.com

Datasheets for electronics components.

National Semiconductor was acquired by Texas Instruments.

http://www.ti.com/corp/docs/investor_relations/pr_09_23_2011_national_semiconductor.html

This file is the datasheet for the following electronic components:

54F160A - <http://www.ti.com/product/54f160a?HQS=TI-null-null-dscatalog-df-pf-null-ww>

74F160A - <http://www.ti.com/product/74f160a?HQS=TI-null-null-dscatalog-df-pf-null-ww>

74F162A - <http://www.ti.com/product/74f162a?HQS=TI-null-null-dscatalog-df-pf-null-ww>