

MEDIUM-SPEED SWITCH

DESCRIPTION

The 2N4036 is a silicon planar epitaxial PNP transistor in Jedec TO-39 metal case. It is intended particularly as medium speed saturated switch and general purpose amplifier.

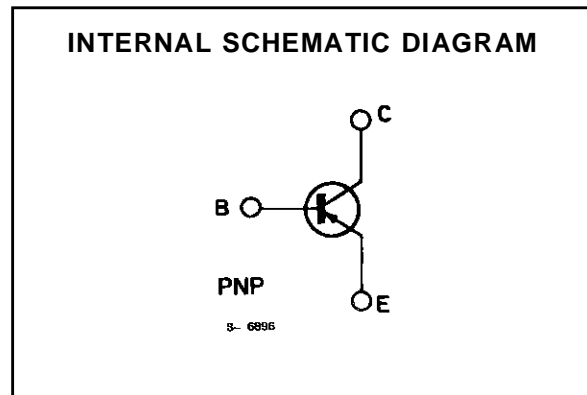
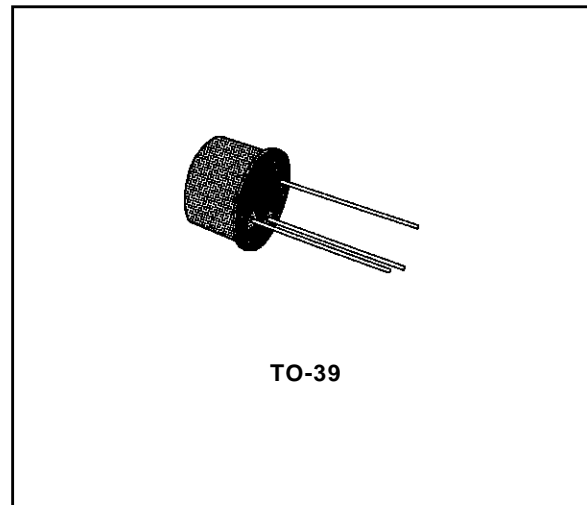

ABSOLUTE MAXIMUM RATINGS

Symbol	Parameter	Value	Unit
V_{CBO}	Collector-base Voltage ($I_E = 0$)	- 90	V
V_{CEX}	Collector-emitter Voltage ($V_{BE} = 1.5$ V)	- 85	V
V_{CER}	Collector-emitter Voltage ($R_{BE} \leq 200 \Omega$)	- 85	V
V_{CEO}	Collector-emitter Voltage ($I_B = 0$)	- 65	V
V_{EBO}	Emitter-base Voltage ($I_C = 0$)	- 6	V
I_C	Collector Current	- 1	A
I_B	Base Current	- 0.5	A
P_{tot}	Total Power Dissipation at $T_{amb} \leq 25$ °C at $T_{case} \leq 25$ °C	1	W
		7	W
T_{stg}, T_j	Storage and Junction Temperature	- 65 to 200	°C

THERMAL DATA

$R_{th\ j-case}$	Thermal Resistance Junction-case	Max	25	$^{\circ}C/W$
$R_{th\ j-amb}$	Thermal Resistance Junction-ambient	Max	175	$^{\circ}C/W$

ELECTRICAL CHARACTERISTICS ($T_{amb} = 25\ ^{\circ}C$ unless otherwise specified)

Symbol	Parameter	Test Conditions	Min.	Typ.	Max.	Unit
I_{CBO}	Collector Cutoff Current ($I_E = 0$)	$V_{CB} = -60\ V$			- 20	nA
I_{CEO}	Collector Cutoff Current ($I_B = 0$)	$V_{CE} = -30\ V$			- 0.5	μA
I_{EBO}	Emitter Cutoff Current ($I_C = 0$)	$V_{EB} = -5\ V$			- 20	nA
$V_{(BR)CBO}$	Collector-base Breakdown Voltage ($I_E = 0$)	$I_C = -100\ \mu A$	- 90			V
$V_{(BR)CEX}^*$	Collector-emitter Breakdown Voltage ($V_{BE} = 1.5\ V$)	$I_C = -10\ mA$	- 85			V
$V_{(BR)CER}^*$	Collector-emitter Breakdown Voltage ($R_{BE} = 200\ \Omega$)	$I_C = -10\ mA$	- 85			V
$V_{(BR)CEO}^*$	Collector-emitter Breakdown Voltage ($I_B = 0$)	$I_C = -10\ mA$	- 65			V
$V_{(BR)EBO}$	Emitter-base Breakdown Voltage ($I_C = 0$)	$I_E = -100\ \mu A$	- 7			V
$V_{CE(sat)}^*$	Collector-emitter Saturation Voltage	$I_C = -150\ mA$ $I_B = -15\ mA$			- 0.65	V
V_{BE}^*	Base-emitter Voltage	$I_C = -150\ mA$ $V_{CE} = -10\ V$			- 1.1	V
h_{FE}^*	DC Current Gain	$I_C = -0.1\ mA$ $V_{CE} = -10\ V$ $I_C = -150\ mA$ $V_{CE} = -10\ V$ $I_C = -500\ mA$ $V_{CE} = -10\ V$	20 40 20		140	
f_T	Transition Frequency	$I_C = -50\ mA$ $V_{CE} = -10\ V$ $f = 20\ MHz$	60			MHz
C_{EBO}	Emitter-base Capacitance	$I_C = 0$ $V_{EB} = -0.5\ V$ $f = 1\ MHz$			90	pF
C_{CBO}	Collector-base Capacitance	$I_E = 0$ $V_{CB} = -10\ V$ $f = 1\ MHz$			30	pF
t_{on}^{**}	Turn-on Time	$I_C = -150\ mA$ $V_{CC} = -30V$ $I_{B1} = -15\ mA$			110	ns
t_{off}^{**}	Turn-off Time	$I_C = -150\ mA$ $V_{CC} = -30\ V$ $I_{B1} = -I_{B2} = -15\ mA$			700	ns

* Pulsed : pulse duration = 300 μs , duty cycle = 1 %.

** See test circuit.

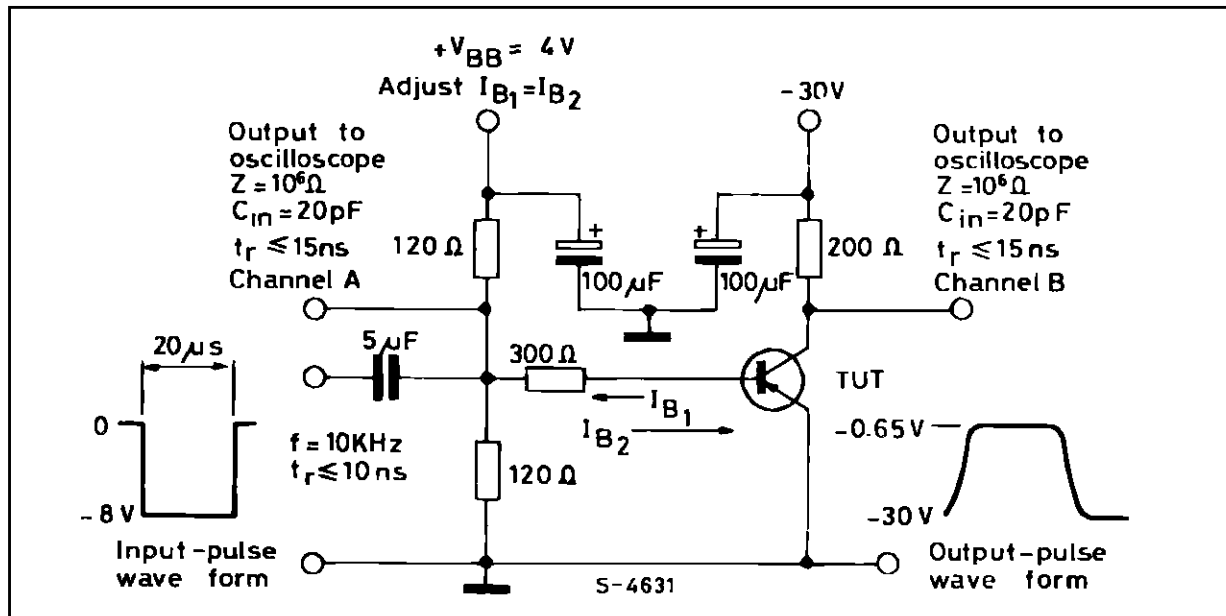
Test Circuit for t_{on} , t_{off} .

TO39 MECHANICAL DATA

DIM.	mm			inch		
	MIN.	TYP.	MAX.	MIN.	TYP.	MAX.
A	12.7			0.500		
B			0.49			0.019
D			6.6			0.260
E			8.5			0.334
F			9.4			0.370
G	5.08			0.200		
H			1.2			0.047
I			0.9			0.035
L	45° (typ.)					

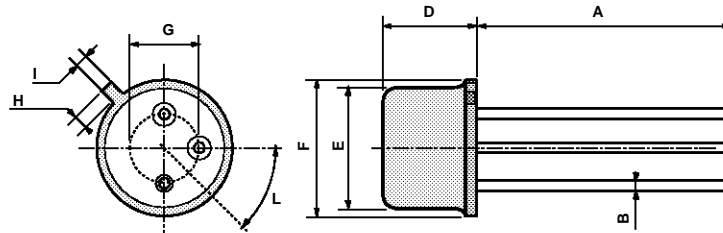

P008B

Information furnished is believed to be accurate and reliable. However, SGS-THOMSON Microelectronics assumes no responsibility for the consequences of use of such information nor for any infringement of patents or other rights of third parties which may result from its use. No license is granted by implication or otherwise under any patent or patent rights of SGS-THOMSON Microelectronics. Specifications mentioned in this publication are subject to change without notice. This publication supersedes and replaces all information previously supplied. SGS-THOMSON Microelectronics products are not authorized for use as critical components in life support devices or systems without express written approval of SGS-THOMSON Microelectronics.

© 1994 SGS-THOMSON Microelectronics - All Rights Reserved

SGS-THOMSON Microelectronics GROUP OF COMPANIES

Australia - Brazil - France - Germany - Hong Kong - Italy - Japan - Korea - Malaysia - Malta - Morocco - The Netherlands -
Singapore - Spain - Sweden - Switzerland - Taiwan - Thailand - United Kingdom - U.S.A

This datasheet has been download from:

www.datasheetcatalog.com

Datasheets for electronics components.