

**Commercial
Industrial**

**X9MME
X9MMEI**

E²POT™ Digitally Controlled Potentiometer

FEATURES

- Solid State Reliability
- Single Chip MOS Implementation
- Three Wire TTL Control
- Operates From Standard 5V Supply
- 99 Resistive Elements
 - Temperature Compensated
 - ± 20% End to End Resistance Range
- 100 Wiper Tap Points
 - Wiper Position Digitally Controlled
 - Wiper Position Stored in Nonvolatile Memory Then Automatically Recalled on Power-Up
- 100 Year Wiper Position Retention
- 8 Pin Mini-DIP Package
- 14 Pin SOIC Package

DESCRIPTION

The Xicor X9MME is a solid state nonvolatile potentiometer and is ideal for digitally controlled resistance trimming.

The X9MME is a resistor array composed of 99 resistive elements. Between each element and at either end are tap points accessible to the wiper element. The position of the wiper element on the array is controlled by the \overline{CS} , U/\overline{D} , and \overline{INC} inputs. The position of the wiper can be stored in nonvolatile memory and is recalled upon a subsequent power-up.

The resolution of the X9MME is equal to the maximum resistance value divided by 99. As an example; for the X9503 (50 K Ω) each tap point represents 505 Ω .

Xicor E² products are designed and tested for applications requiring extended endurance. Refer to Xicor reliability reports for further endurance information.

4

PIN CONFIGURATIONS

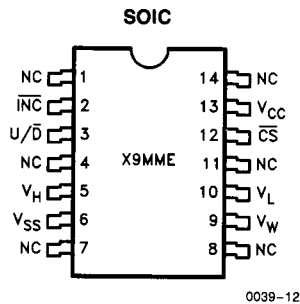
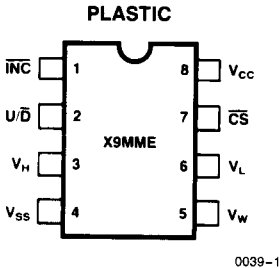

PIN NAMES

V_H	High Terminal of Pot
V_W	Wiper Terminal of Pot
V_L	Low Terminal of Pot
V_{SS}	Ground
V_{CC}	System Power
U/\overline{D}	Up/Down Control
\overline{INC}	Wiper Movement Control
\overline{CS}	Chip Select for Wiper Movement/Storage
NC	No Connect

X9MME, X9MMEI

ANALOG CHARACTERISTICS

Electrical Characteristics

End to End Resistance Tolerance	± 20%
Power Rating at 25°C	
X9102	16 mW
X9103, X9503 and X9104	10 mW
Wiper Current	± 1 mA Max.
Typical Wiper Resistance	40Ω at 1 mA
Typical Noise	
X9102	< -120 dB/√Hz Ref: 1V
X9103, X9503 and X9104	< -95 dB/√Hz Ref: 1V

Resolution

Resistance	1%
------------	----

Linearity

Absolute Linearity ⁽¹⁾	± 1.0 MI(2)
Relative Linearity ⁽³⁾	± 0.2 MI(2)

Temperature Coefficient

-40°C to +85°C	
X9102	± 600 ppm/°C Typical
X9103, X9503 and X9104	± 300 ppm/°C Typical
Ratiometric Temperature Coefficient	± 20 ppm

Wiper Adjustability

Unlimited Wiper Adjustment (Volatile Mode While Chip is Selected)	
Nonvolatile Storage of Wiper Position	10,000 Cycles Typical

Environmental Characteristics

Temperature Range	
Operating X9MME	-40°C to +70°C
X9MMEI	-40°C to +85°C
Storage	-65°C to +150°C

Physical Characteristics

Marking Includes:	
Manufacturer's Trademark	
Resistance Value or Code	
Date Code	

ABSOLUTE MAXIMUM RATINGS*

Temperature Under Bias	-65°C to +135°C
Storage Temperature	-65°C to +150°C
Voltage on CS, $\overline{\text{INC}}$, U/ $\overline{\text{D}}$ and V_{CC}	
Referenced to Ground	-1.0V to +7.0V
Voltage on V_{H} and V_{L}	
Referenced to Ground	-8.0V to +8.0V
Lead Temperature (Soldering, 10 Seconds)	+300°C
Wiper Current	± 1 mA
$\Delta V = V_{\text{H}} - V_{\text{L}} $	
X9102	4V
X9103, X9503 and X9104	10V

*COMMENT

Stresses above those listed under "Absolute Maximum Ratings" may cause permanent damage to the device. This is a stress rating only and the functional operation of the device at these or any other conditions above those indicated in the operational sections of this specification is not implied. Exposure to absolute maximum rating conditions for extended periods may affect device reliability.

D.C. OPERATING CHARACTERISTICS

X9MME $T_{\text{A}} = 0^{\circ}\text{C}$ to $+70^{\circ}\text{C}$, $V_{\text{CC}} = +5\text{V} \pm 10\%$, unless otherwise specified.

X9MMEI $T_{\text{A}} = -40^{\circ}\text{C}$ to $+85^{\circ}\text{C}$, $V_{\text{CC}} = +5\text{V} \pm 10\%$, unless otherwise specified.

Symbol	Parameter	Limits			Units	Test Conditions
		Min.	Typ. ⁽⁴⁾	Max.		
I_{CC}	Supply Current		25	35	mA	
I_{LI}	Input Leakage Current			± 10	μA	$V_{\text{IN}} = 0\text{V}$ to 5.5V, $\overline{\text{INC}}$, U/ $\overline{\text{D}}$, CS
V_{IH}	Input High Voltage	2.0		$V_{\text{CC}} + 1.0$	V	
V_{IL}	Input Low Voltage	-1.0		0.8	V	
R_{W}	Wiper Resistance		40	100	Ω	± 1 mA
$V_{\text{VH}}^{(5)}$	V_{H} Voltage	-5.0		+5.0	V	
$V_{\text{VL}}^{(5)}$	V_{L} Voltage	-5.0		+5.0	V	
$C_{\text{IN}}^{(6)}$	CS, $\overline{\text{INC}}$, U/ $\overline{\text{D}}$, Input Capacitance			10	pF	

Notes: (1) Absolute Linearity is utilized to determine actual wiper voltage versus expected voltage as determined by wiper position when used as a potentiometer.

$$\text{Absolute Linearity} = (V_{\text{W}(n)}(\text{actual}) - V_{\text{W}(n)}(\text{expected})) = \pm 1 \text{ MI Max.}$$

$$(2) 1 \text{ MI} = R_{\text{TOT}}/99 \text{ or } \frac{V_{\text{H}} - V_{\text{L}}}{99} = \text{Minimum Increment.}$$

(3) Relative Linearity is utilized to determine the actual change in voltage between successive tap position when used as a potentiometer. It is a measure of the error in step size.

$$\text{Relative Linearity} = V_{\text{W}(n+1)} - [V_{\text{W}(n)} + \text{MI}] = \pm 0.2 \text{ MI Max.}$$

Typical values of Linearity are shown in Figures 3, 6, 9 and 12.

(4) Typical values are for $T_{\text{A}} = 25^{\circ}\text{C}$ and nominal supply voltage.

(5) ΔV for X9102 = $|V_{\text{H}} - V_{\text{L}}| \leq 4\text{V}$. ΔV for X9103, X9503 and X9104 = $|V_{\text{H}} - V_{\text{L}}| \leq 10\text{V}$.

(6) This parameter is periodically sampled and not 100% tested.

X9MME, X9MMEI

A.C. CONDITIONS OF TEST

Input Pulse Levels	0V to 3.0V
Input Rise and Fall Times	10 ns
Input	1.5V

MODE SELECTION

\overline{CS}	\overline{INC}	U/\overline{D}	Mode
L		H	Wiper Up
L		L	Wiper Down
	H	X	Store Wiper Position

A.C. CHARACTERISTICS

X9MME $T_A = 0^\circ\text{C}$ to $+70^\circ\text{C}$, $V_{CC} = +5V \pm 10\%$, unless otherwise specified.

X9MMEI $T_A = -40^\circ\text{C}$ to $+85^\circ\text{C}$, $V_{CC} = +5V \pm 10\%$, unless otherwise specified.

Symbol	Parameter	Limits			Units
		Min.	Typ.(7)	Max.	
t_{CI}	\overline{CS} to \overline{INC} Setup	100			ns
t_{ID}	\overline{INC} High to U/\overline{D} Change	100			ns
t_{DI}	U/\overline{D} to \overline{INC} Setup	2.9			μs
t_{iL}	\overline{INC} Low Period	1			μs
t_{iH}	\overline{INC} High Period	3			μs
t_{iC}	\overline{INC} Inactive to \overline{CS} Inactive	1			μs
t_{CPH}	\overline{CS} Deselect Time	20			ms
t_{iW}	\overline{INC} to V_W Change		100	500	μs

4

A.C. Timing

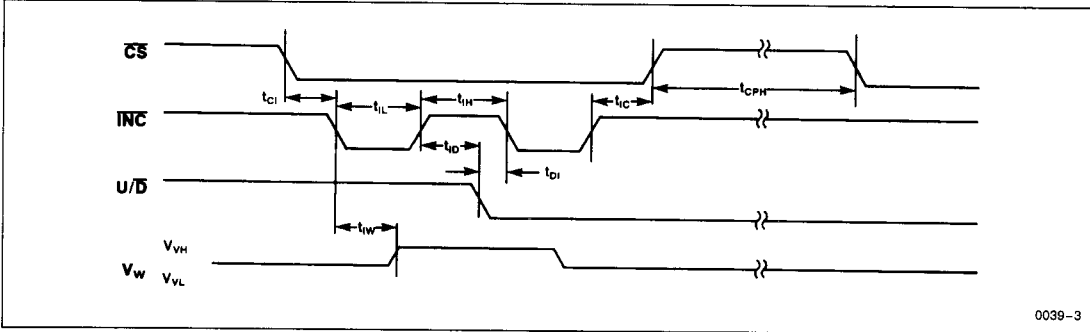

Note: (7) Typical values are for $T_A = 25^\circ\text{C}$ and nominal supply voltage.

X9MME, X9MMEI

PIN DESCRIPTIONS

V_H

The high terminal of the X9MME is capable of handling an input voltage from $-5V$ to $+5V$.

V_L

The low terminal input is limited from $-5V$ to $+5V$.

V_W

The wiper terminal series resistance is typically less than 40Ω . The value of the wiper is controlled by the use of U/\bar{D} and \bar{INC} .

Up/Down (U/\bar{D})

The U/\bar{D} input controls the direction of the wiper movement and the value of the nonvolatile counter.

Increment (\bar{INC})

The \bar{INC} input is negative-edge triggered. Toggling \bar{INC} will move the wiper and either increment or decrement the counter in the direction indicated by the logic level on the U/\bar{D} input.

Chip Select (\bar{CS})

The device is selected when the \bar{CS} input is LOW. The current counter value is stored in nonvolatile memory when \bar{CS} is returned HIGH with \bar{INC} HIGH.

DEVICE OPERATION

The \bar{INC} , U/\bar{D} and \bar{CS} inputs control the movement of the wiper along the resistor array. HIGH to LOW transitions on \bar{INC} , with \bar{CS} LOW, increment ($U/\bar{D} = \text{HIGH}$) or decrement ($U/\bar{D} = \text{LOW}$) an internal counter. The output of the counter is decoded to position the wiper. When \bar{CS} is brought HIGH the counter value is automatically stored in the nonvolatile memory. Upon power-up the nonvolatile memory contents are restored to the counter.

With the wiper at position 99, additional increments ($U/\bar{D} = \text{HIGH}$) will not move the wiper. With the wiper at position 0, additional decrements ($U/\bar{D} = \text{LOW}$) will not move the wiper.

The state of U/\bar{D} may be changed while \bar{CS} remains LOW, allowing a gross then fine adjustment during system calibration.

If V_{CC} is removed while \bar{CS} is LOW the contents of the nonvolatile memory may be lost.

The end to end resistance of the array will fluctuate once V_{CC} is removed.

APPLICATIONS

The combination of a digital interface and nonvolatile memory in a silicon based trimmer pot provides many application opportunities that could not be addressed by either mechanical potentiometers or digital to analog circuits. The X9MME addresses and solves many issues that are of concern to designers of a wide range of equipment.

Consider the possibilities:

Automated assembly line calibration versus mechanical tweaking of potentiometers.

Protection against drift due to vibration or contamination.

Eliminate precise alignment of PWB mounted potentiometers with case access holes.

Eliminate unsightly access holes on otherwise aesthetically pleasing enclosures.

Product enhancements such as keyboard adjustment of volume or brightness control.

Front panel microprocessor controlled calibration of test instruments.

Remote location calibration via radio, modem or LAN link.

Calibration of hard to reach instruments in aircraft or other confined spaces.

APPLICATION CIRCUITS

Application Circuit # 1

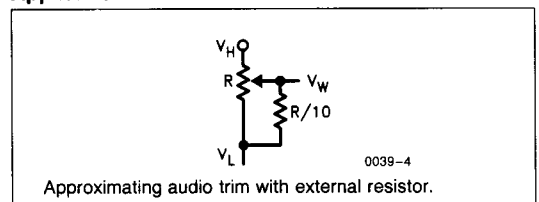

Application Circuit # 2

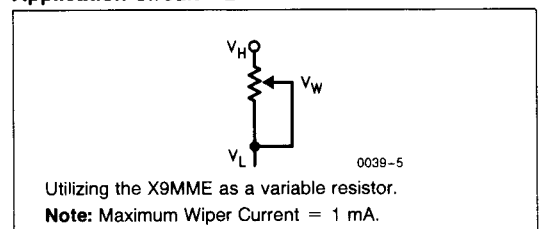

X9MME, X9MMEI

Figure 1: Typical Frequency Response for X9102

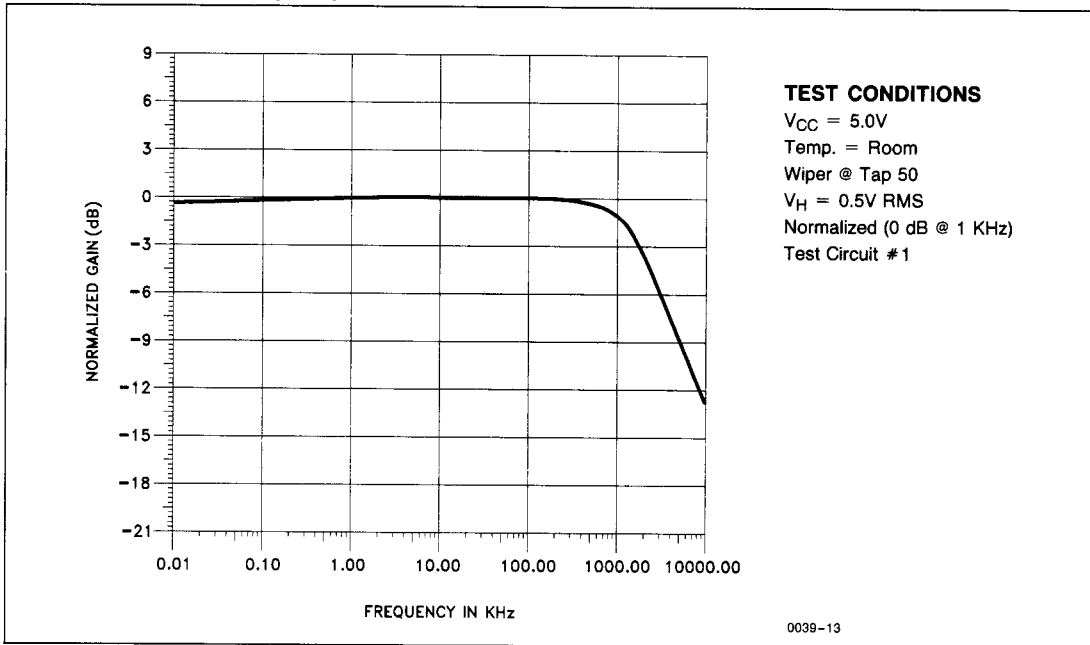

4

Figure 2: Typical Total Harmonic Distortion for X9102

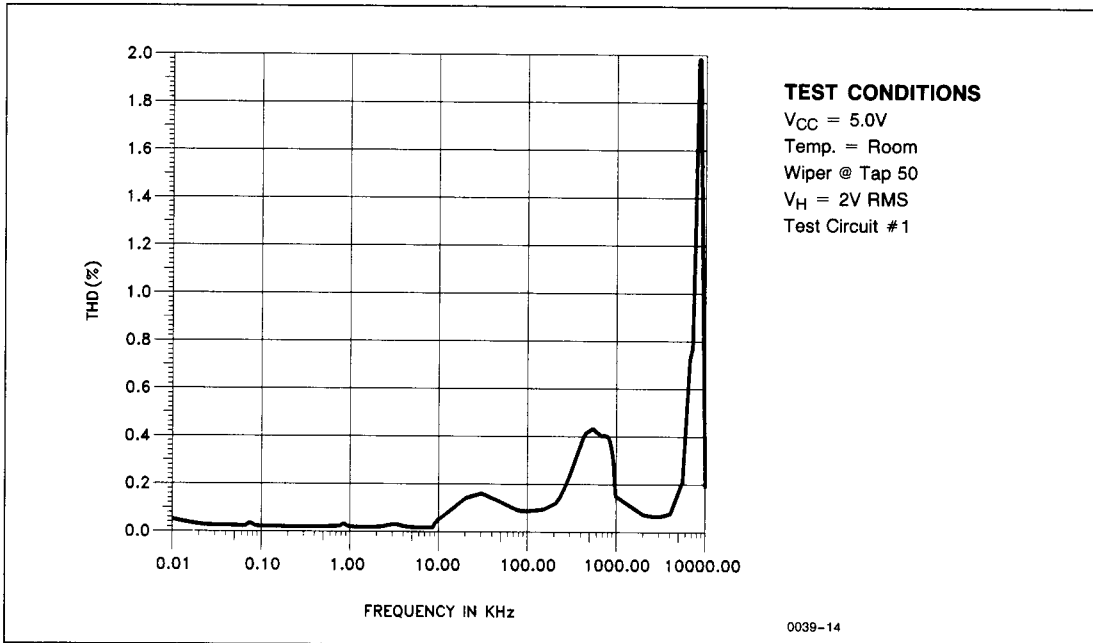

X9MME, X9MMEI

Figure 3: Typical Linearity for X9102

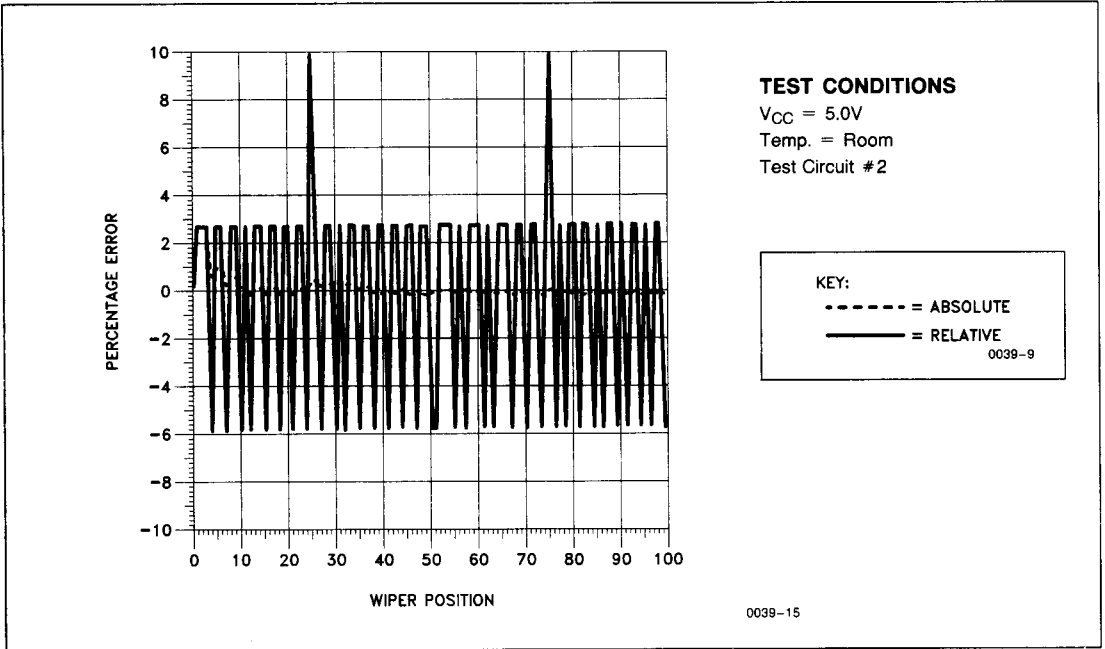
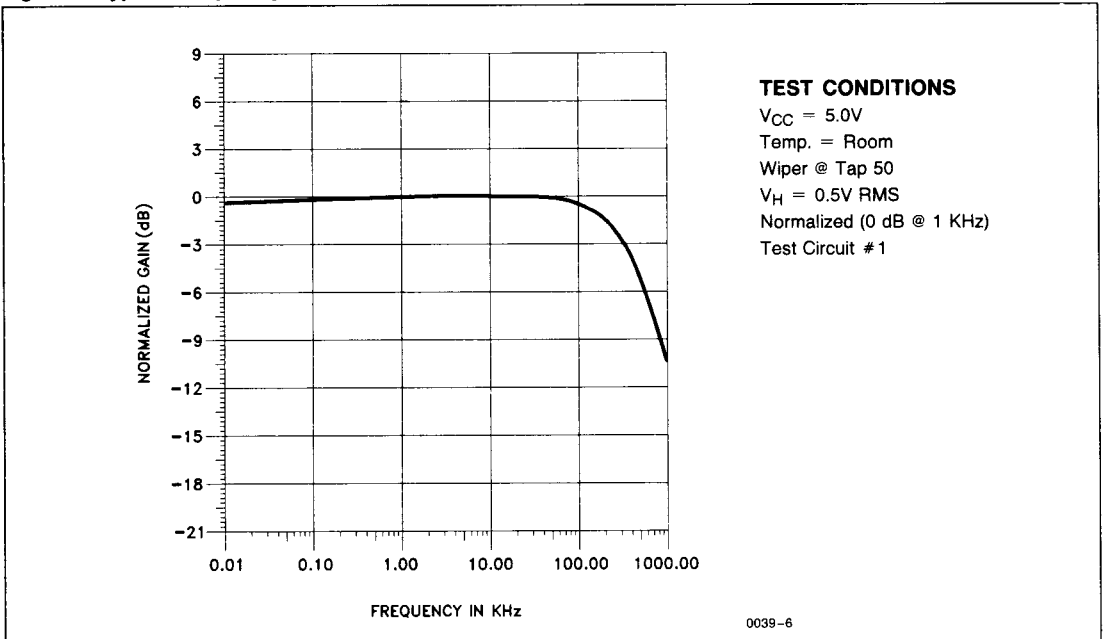
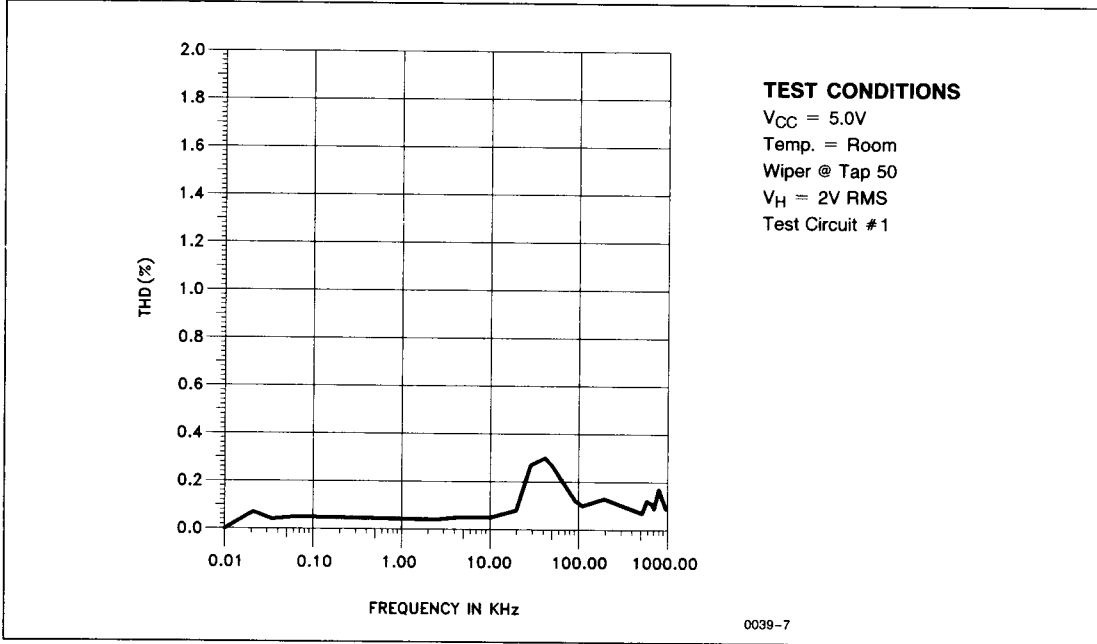

Figure 4: Typical Frequency Response for X9103



X9MME, X9MMEI

Figure 5: Typical Total Harmonic Distortion for X9103



4

Figure 6: Typical Linearity for X9103

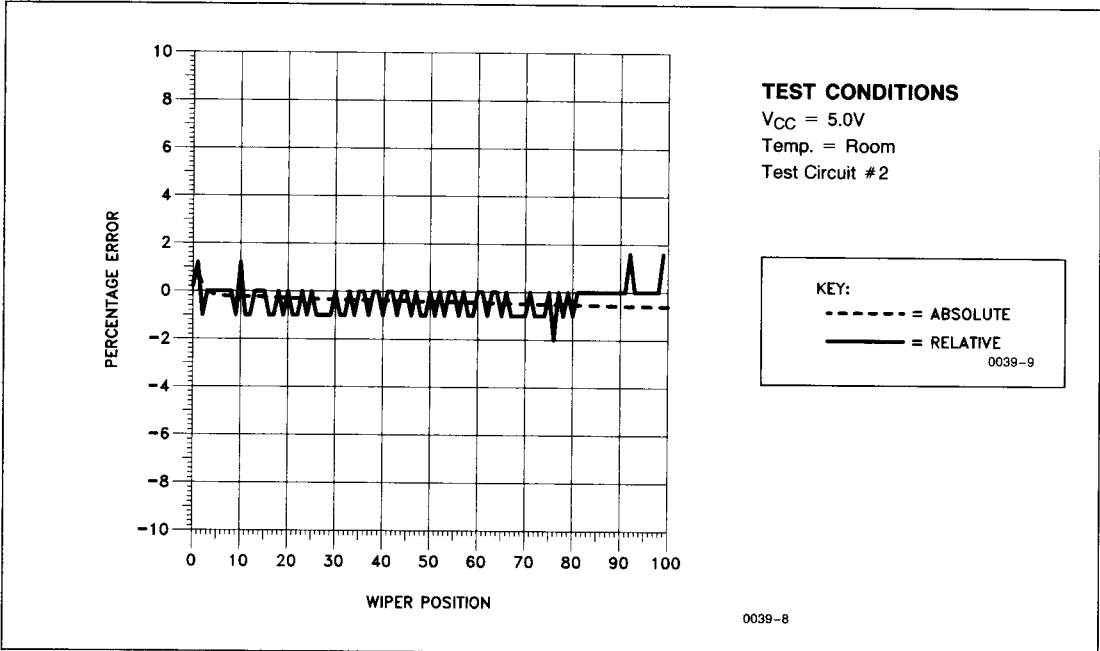

X9MME, X9MMEI

Figure 7: Typical Frequency Response for X9503

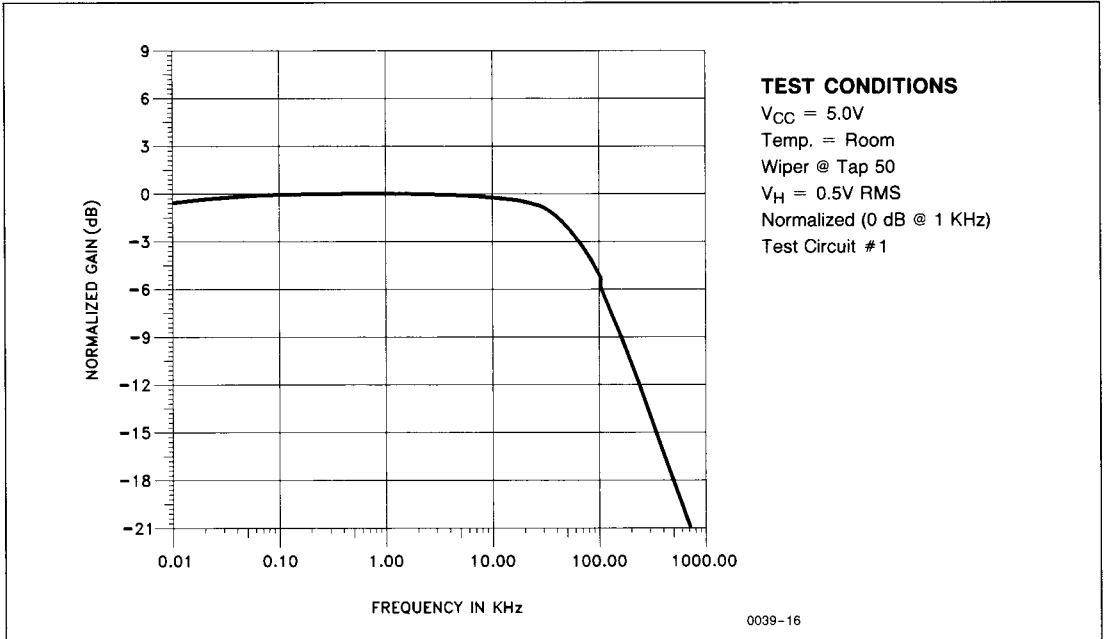
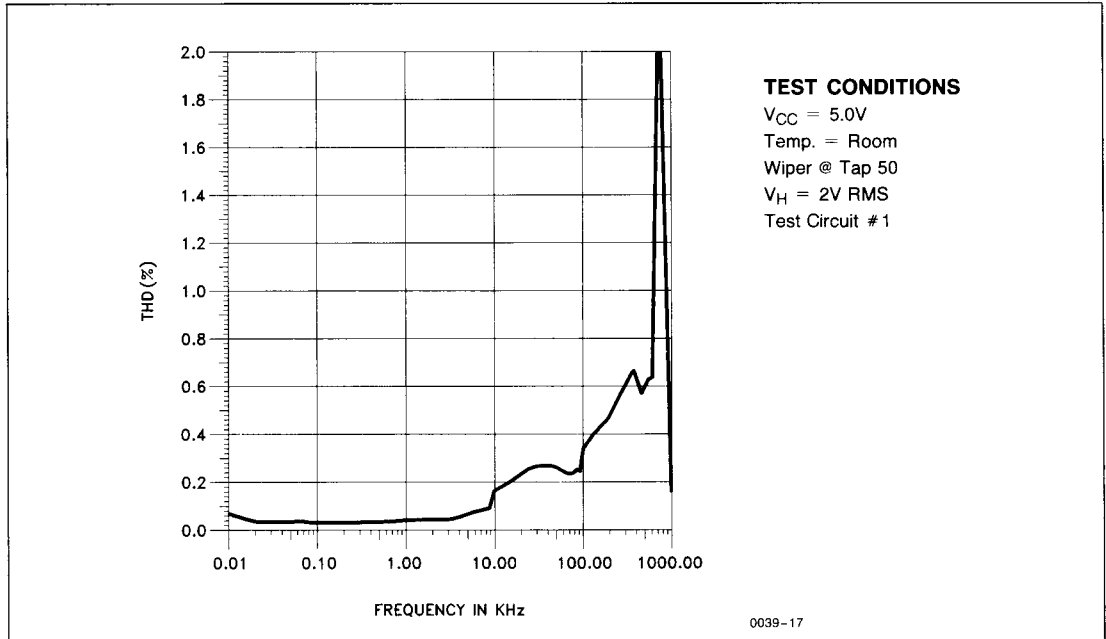
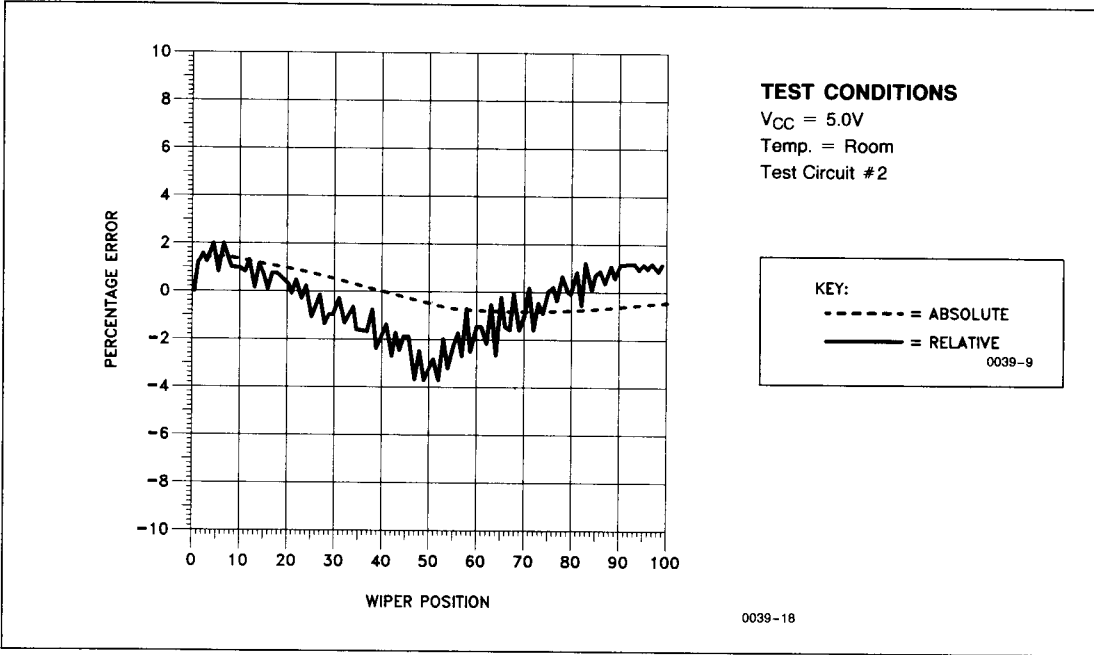

Figure 8: Typical Total Harmonic Distortion for X9503



X9MME, X9MMEI

Figure 9: Typical Linearity for X9503



4

Figure 10: Typical Frequency Response for X9104

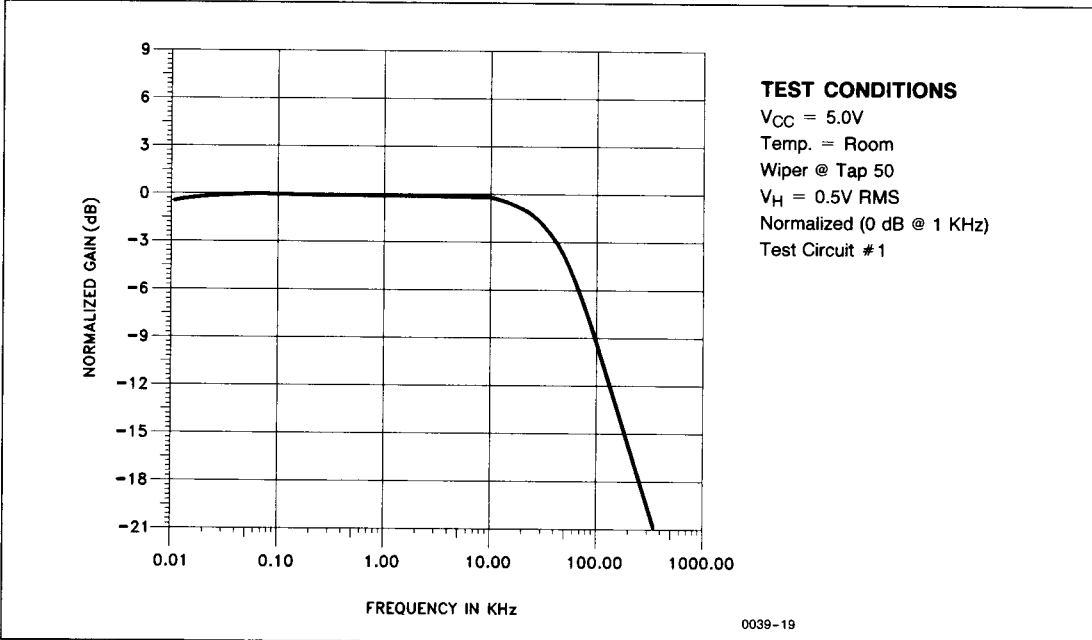

X9MME, X9MMEI

Figure 11: Typical Total Harmonic Distortion for X9104

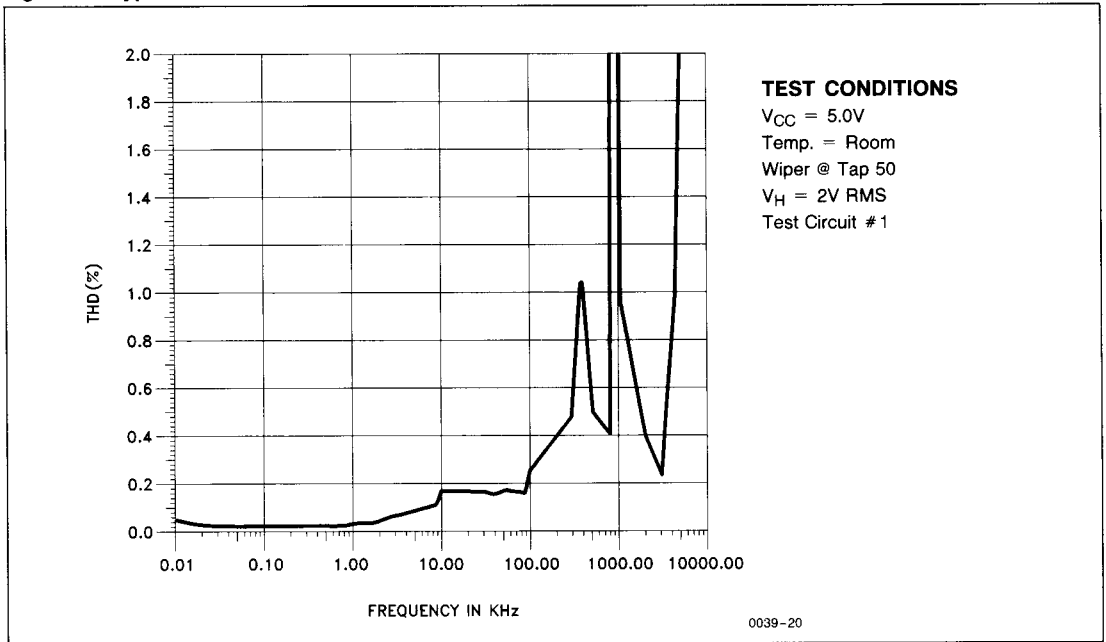
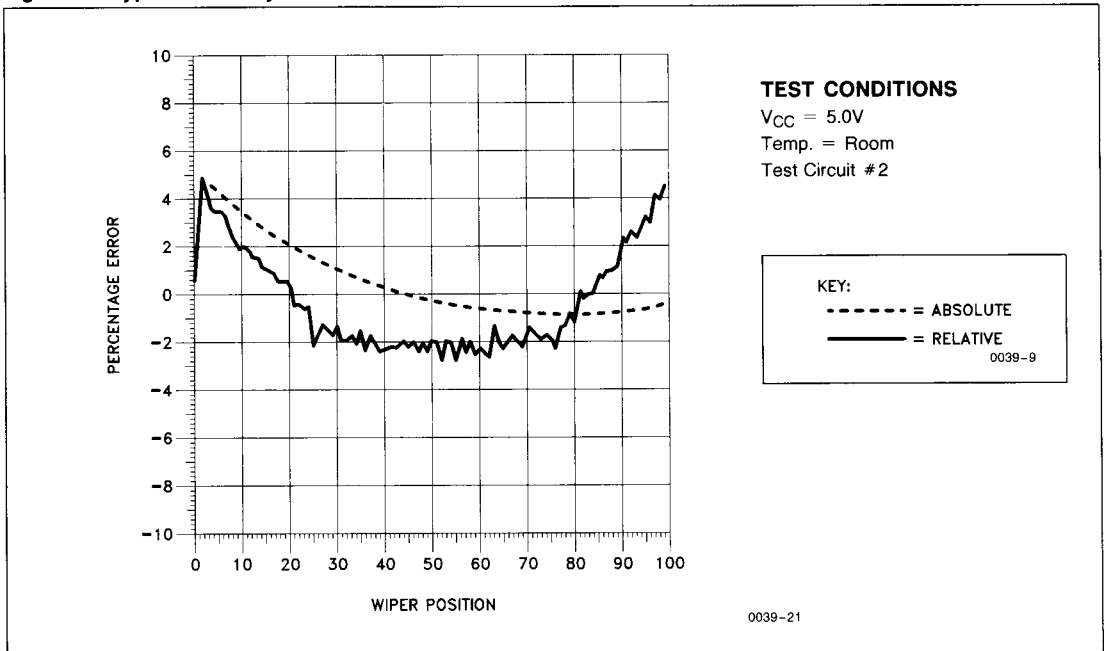
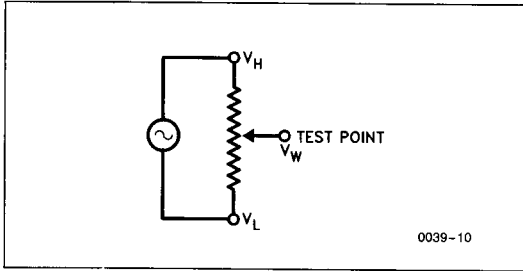

Figure 12: Typical Linearity for X9104



X9MME, X9MMEI

Test Circuit # 1



Test Circuit # 2

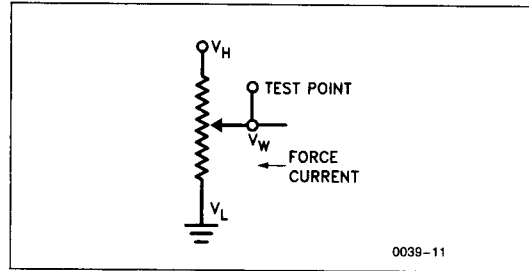

Standard Parts

Minimum Resistance	Wiper Increments	Maximum Resistance	Part Number
40Ω	10.1Ω	1 KΩ	X9102
40Ω	101Ω	10 KΩ	X9103
40Ω	505Ω	50 KΩ	X9503
40Ω	1010Ω	100 KΩ	X9104

4

FUNCTIONAL DIAGRAM

