

3875081 GE SOLID STATE

01E 11058 D



U308-U310
N-Channel JFET
High Frequency Amplifier

FEATURES

- High Power Gain
- Low Noise
- Dynamic Range Greater Than 100dB
- Easily Matched to 75Ω Input

PIN CONFIGURATIONS

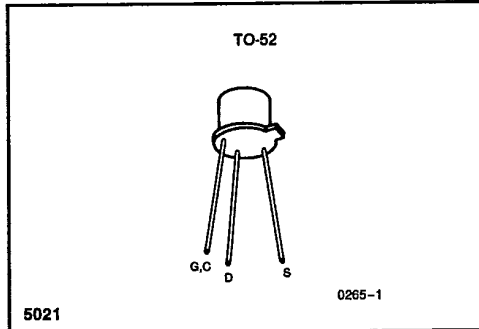

ABSOLUTE MAXIMUM RATINGS

(T_A = 25°C unless otherwise noted)

Gate-Drain or Gate-Source Voltage	-25V
Gate Current	20mA
Storage Temperature	-65°C to +200°C
Operating Temperature Range	-55°C to +150°C
Lead Temperature (Soldering, 10sec)	+300°C
Power Dissipation	500mW
Derate above 25°C	4mW/°C

NOTE: Stresses above those listed under "Absolute Maximum Ratings" may cause permanent damage to the device. These are stress ratings only and functional operation of the device at these or any other conditions above those indicated in the operational sections of the specifications is not implied. Exposure to absolute maximum rating conditions for extended periods may affect device reliability.

ORDERING INFORMATION

TO-52
U308
U309
U310

ELECTRICAL CHARACTERISTICS (T_A = 25°C unless otherwise specified)

Symbol	Parameter	Test Conditions	U308			U309			U310			Units	
			Min	Typ	Max	Min	Typ	Max	Min	Typ	Max		
I _{GSS}	Gate Reverse Current	V _{GS} = -15V			-150			-150			-150	pA	
		V _{GS} = 0			-150			-150			-150	nA	
BV _{GSS}	Gate-Source Breakdown Voltage	I _G = -1μA, V _{DS} = 0	-25			-25			-25			V	
V _{GS(off)}	Gate-Source Cutoff Voltage	V _{DS} = 10V, I _D = 1nA	-1.0		-6.0	-1.0		-4.0	-2.5		-6.0	V	
I _{DSS}	Saturation Drain Current (Note 1)	V _{DS} = 10V, V _{GS} = 0	12		60	12		30	24		60	mA	
V _{GS(f)}	Gate-Source Forward Voltage	I _G = 10mA, V _{DS} = 0			1.0			1.0			1.0	V	
g _{fg}	Common-Gate Forward Transconductance (Note 1)	V _{DS} = 10V, I _D = 10mA	f = 1kHz	10	17		10	17		10	17		μS
						250			250			250	
C _{gd}	Drain-Gate Capacitance	V _{GS} = -10V, V _{DS} = 10V			2.5			2.5			2.5	pF	
C _{gs}	Gate-Source Capacitance				5.0			5.0			5.0	pF	
e _n	Equivalent Short Circuit Input Noise Voltage	V _{DS} = 10V, I _D = 10mA		10			10			10		nV/√Hz	

INTERASIL'S SOLE AND EXCLUSIVE WARRANTY OBLIGATION WITH RESPECT TO THIS PRODUCT SHALL BE THAT STATED IN THE WARRANTY ARTICLE OF THE CONDITION OF SALE. THE WARRANTY SHALL BE EXCLUSIVE AND SHALL BE IN LIEU OF ALL OTHER WARRANTIES, EXPRESS, IMPLIED OR STATUTORY, INCLUDING THE IMPLIED WARRANTIES OF MERCHANTABILITY AND FITNESS FOR A PARTICULAR USE.

NOTE: All typical values have been characterized but are not tested.

U308-U310

INTERSIL

T-31-25

U308-U310

ELECTRICAL CHARACTERISTICS (Continued) ($T_A = 25^\circ\text{C}$ unless otherwise specified)

Symbol	Parameter	Test Conditions	U308			U309			U310			Units	
			Min	Typ	Max	Min	Typ	Max	Min	Typ	Max		
g _{fg}	Common-Gate Forward Transconductance	V _{DS} = 10V, I _D = 10mA	f = 100MHz		15			15			15	μS	
			f = 450MHz		14			14			14		
g _{ogs}	Common-Gate Output Conductance		f = 100MHz		0.18			0.18			0.18		
			f = 450MHz		0.32			0.32			0.32		
G _{pg}	Common-Gate Power Gain		f = 100MHz	14	16		14	16		14	16	dB	
			f = 450MHz	10	11		10	11		10	11		
NF	Noise Figure	(Note 2)	f = 100MHz		1.5	2.0		1.5	2.0		1.5		2.0
		f = 450MHz		2.7	3.5		2.7	3.5		2.7	3.5		

NOTES: 1. Pulse test duration = 2ms.
2. For design reference only, not 100% tested.

10

INTERSIL'S SOLE AND EXCLUSIVE WARRANTY OBLIGATION WITH RESPECT TO THIS PRODUCT SHALL BE THAT STATED IN THE WARRANTY ARTICLE OF THE CONDITION OF SALE. THE WARRANTY SHALL BE EXCLUSIVE AND SHALL BE IN LIEU OF ALL OTHER WARRANTIES, EXPRESS, IMPLIED OR STATUTORY, INCLUDING THE IMPLIED WARRANTIES OF MERCHANTABILITY AND FITNESS FOR A PARTICULAR USE.

NOTE: All typical values have been characterized but are not tested.

This datasheet has been downloaded from:

www.DatasheetCatalog.com

Datasheets for electronic components.